

# **MD Series Modular Vector Inverter**

<b>Preface</b>
<b>Safety and Cautions</b>
<b>Product Information</b>
<b>Mechanical and Electrical Installation</b>
<b>Operation and Display</b>
<b>Function Parameters</b>
<b>Parameter Description</b>
<b>Fault Diagnosis and Countermeasures</b>

## **MD300 User's Manual ( V1.2 )**

# **MD Series Modular Vector Inverter**

## **User's Manual**

---

**Inovance Technology Co., Ltd. will provide you a full-set of technical supports. Please feel free to contact our local sales offices or service center. You may also contact us directly.**

**Copyright by Inovance Technology Co., Ltd.**

**All rights reserved**

## **Inovance Technology Co., Ltd.**

## Contents

**Contents**

<b>Chapter 1 Safety and Cautions</b> .....	3
1.1 Safety Cautions .....	3
1.2 Cautions.....	3
<b>Chapter 2 Product Information</b> .....	3
2.1 Name Designation Rules .....	3
2.2 Nameplate .....	3
2.3 MD300 Series of Inverter .....	3
2.4 Technical Specification.....	3
2.5 Product Appearance and Dimension of Installation Holes .....	3
2.6 Optional Parts .....	3
2.7 Daily Maintenance of Inverter .....	3
2.8 Warranty .....	3
2.9 Model Selection .....	3
2.10 Selecting Braking Units.....	3
<b>Chapter 3 Mechanical and Electrical Installation</b> .....	3
3.1 Mechanical Installation.....	3
3.2 Electrical Installation .....	3
<b>Chapter 4 Operation and Display</b> .....	3
4.1 Operation and Display Interface .....	3
4.2 Modify and Check the Function Codes .....	3
4.3 How to View Status Parameters.....	3
4.4 Password Setting .....	3
4.5 Auto Tuning of Motor Parameters .....	3
<b>Chapter 5 Function Parameters</b> .....	3
<b>Chapter 6 Parameter Description</b> .....	3
F0 Group: Basic Function Group .....	3
F1 Group: Motor Parameters .....	3
F2 Group: Vector Control and V/F Control Parameters .....	3
F3 Group: Terminal Input and Output.....	3
F4 Group: Start and Stop Control Parameters .....	3
F5 Group: Fault and Protection.....	3
F6 Group: Auxiliary Function.....	3
FF Group: Manufacturer Parameter.....	3
FP Group: User Password .....	3
<b>Chapter 7 Fault Diagnosis and Countermeasures</b> .....	3
7.1 Fault Alarm and Countermeasures .....	3
7.2 Common Faults and the Fault Diagnosis .....	3



## Preface

MD series inverter, presented by Inovance Technology, is a new-generation high performance modular inverter that represents the future development of inverter. Compared with the traditional inverter, it satisfies the requirements of customers on performance and functions by a customized platform instead of several series of products that may increase the cost of manufacturing, sales, application and maintenance. This platform is established on the basis of the segmentation of the customer requirements, on which the modular design is conducted through the flexible combination of several modules of single series of products.

MD series inverter creates three new concepts for the future generation of inverters:

- 1: It initially creates the 3-layer modular architecture standard of the new generation inverter, as shown in Fig. 1.
- 2: It creates the physical standard for dividing the main function modules such as motor drive, universal function and specialized function and various submodules according to the user's requirement, as shown in Fig. 2.
- 3: It leads the new trend of popularization of vector control technology.

These concepts shall influence the inverter industry profoundly.

The bottom layer, middle layer and top layer are described as follows:

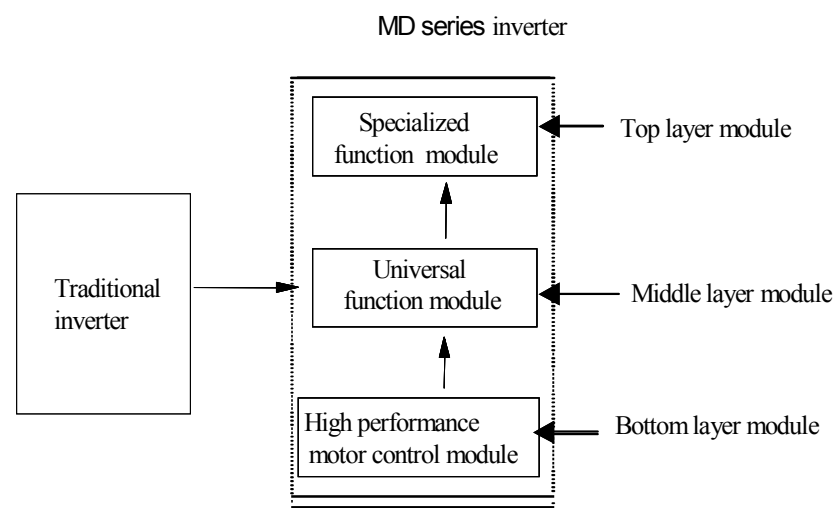

Fig. 1 Comparison between traditional inverter and MD series inverter

- 1) The module in the bottom layer of MD series inverter is the high performance motor control module that comprises the V/F, speed-sensor-less vector control (SVC) and vector control (VC) The module performs the high performance control and comprehensive protection to the motor, and

Chapter 1 Safety and Cautions

it controls the motor through multi-channel to receive the running command and performs the close loop vector control through the pulse coding interface.

- 2) The module in the middle layer of MD series inverter is the universal functional module, which realizes the basic functions of the inverter such as PID control, MS speed and wobble frequency. We offer two sub-modules for customers according to the complexity of the functions, which are MD300 functional module and MD320 functional module. The function differences are given in table 1.

	MD320	MD300
Input/output terminal	5×DI (bi-direction input and one high speed port), 2×AI, 2×DO (one high speed port), 1×AO, several extendable I/O ports	4×DI (single-direction input and one high speed port), 2×AI, 1×DO, 1×AO
Control mode	SVC, VC, V/F	SVC, V/F
Analog reference mode	Straight line mode	Multi-point broken line mode to enable the function of injection machine
MS-speed	16 segments speed	4 segments speed
Simple PLC	16 segments of timed operation	None
Wobble frequency and fixed length control	Yes	None
Master/slave reference	Master/slave reference for any channel	Only AI2 can be auxiliary reference.
Communication function	Through extended card	Through special card
PID control	Yes	None
Multi-point V/F	Yes	None

Table 1 Differences between MD320 and MD300 functional module

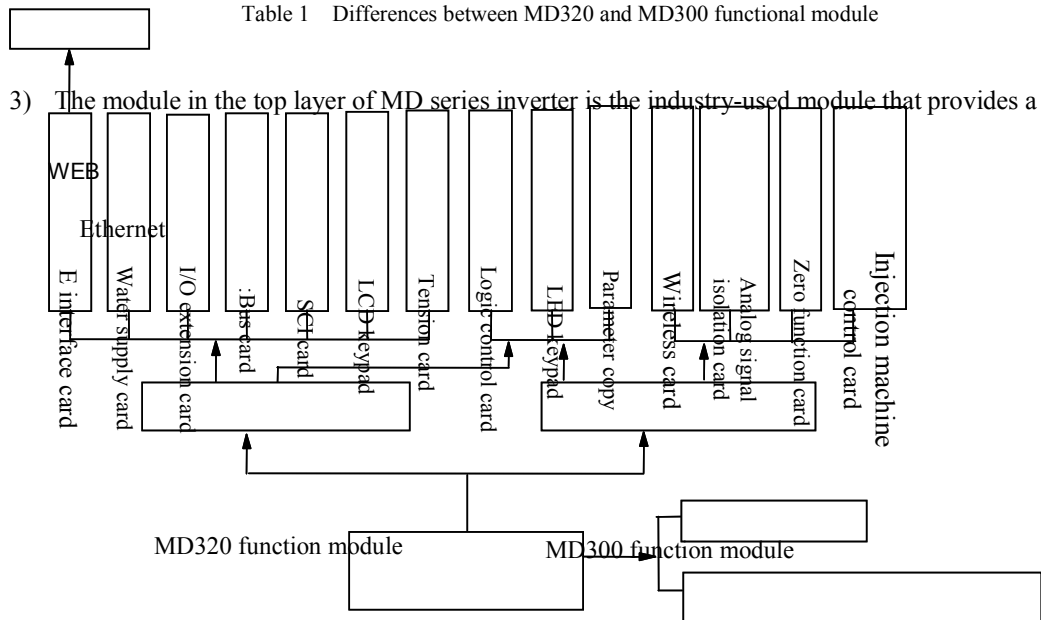



High performance motor  
control module

Common PG card

PG card with frequency dividing

Fig.2 Architecture of MD series inverter

## Chapter 1 Safety and Cautions

solution platform for the specialized requirement in the industry and the users can develop their own solutions based on the module according to his actual needs. The module is shown in Fig. 2.

In product design, the MD series inverter has its special characteristics. It has independent air ventilation channels and the radiator that can be installed in or outside the cabinet, which can provide the solution close to IP54 protection requirements. The direct-input DC bus terminal and DC power supply for fan enable the product to be compatible with the shared DC bus operation mode. Perfect user password protection and quick menu design make the commissioning easier. The interface of the panel and the communication port use the standard RJ45 port, which ensures the reliability and the low application cost. MODBUS RTU protocol is the standard protocol with extended card is compatible with such bus control as PROFIBUS, DeviceNet and CANopen, and the functional extended card can be identified automatically. All these features represent the designing rule of “Customer First” for MD series inverter.

This manual is the operational guidance for MD series inverter and MD320 control module. Please refer to the operation manual for the use of MD300 control module.

This manual provides the guidance for model selection, installation, parameter configuration, field commissioning and trouble shooting, daily maintenance, relevant cautions and guidance for maintenance. In order to correctly use this series of inverter, please read the manual thoroughly and keep it carefully for later use. For the equipment support customers, please deliver the manual together with the equipment to the end user.

**Notes for unpacking inspection:**

Upon unpacking, please confirm the following:

- 1) Check whether the model and the rated values on the nameplate of the inverter are in accordance with your order. The box contains the product you order, the QC, operation manual and the warranty card.
- 2) Check if there is any damage occurred during transportation; Please contact us or the distributor if you find any missing or damage of the products.

**For first time user:**

In order to use this product correctly, the user who uses the product for the first time must read this manual carefully, and consult our technical support engineer for any questions on the function or performance.

The manual is subject to revision without notice due to the continued improvement of the products.

## Chapter 1 Safety and Cautions

### Safety Definition

There are two kinds of safety cautions in the manual:

 **Danger** Operations which are not performed according to the requirements may cause severe hurt or even death.

 **Note** Operations which are not performed according to requirements may cause moderate hurt or light hurt or equipment damage.

### 1.1 Safety Cautions

#### 1. Before Installation

 **Danger**

- Do not use the inverter that is damaged or has defect, or there will be danger of injury.

#### 2. During Installation

 **Danger**

- Mount the inverter on incombustible surface like metal, and keep away from flammable substances! Otherwise it may cause fire.

 **Note**

- When more than two inverters are to be installed in one cabinet, please pay attention to the installation locations to ensure the cooling effect (refer to Chapter 3 Mechanical and Electrical Installation).
- Do not drop the lead wire stub or screw in the inverter, or the inverter may be damaged.





## Chapter 1 Safety and Cautions

**3. Wiring****! Danger**

- Only the qualified electrical engineer can perform the wiring, otherwise there will be danger of electric shock.
- A circuit breaker must be installed between the mains and the inverter, otherwise there will be danger of fire.
- Wiring can only be done after the mains input is cut off, otherwise there will be danger of electric shock.
- Please connect the inverter to the ground according to the standard, otherwise there will be danger of electric shock.

**Note**

- Do not connect the input terminals with the output terminals (U, V, W), otherwise the inverter may be damaged!
- Ensure the wiring meet the EMC requirements and the local safety standard. The wire size shall be determined according to the manual, otherwise accident may occur!
- Brake resistor must not be connected between the DC bus terminals (+) and (-), otherwise fire may occur!

**4. Before Power-on****Danger**

- Please confirm the mains voltage level is consistent with that of the inverter and the input and output wirings are correct, and check if there is any short circuit in peripheral circuit and if the wiring is fixed and fast, otherwise the inverter may be damaged!
- Mount the cover plate properly before power-on the inverter, otherwise there will be danger of electric shock.

**Note**

- Dielectric strength test had been done at factory. Therefore, user needs not do this test again, otherwise accident may occur!

- All the peripheral parts shall be connected correctly according to the manual, or accident may occur!



### 5. After Power-on

! Danger

- Do not open the cover of the inverter after power-on, otherwise there will be danger of electric shock!
- Do not touch the inverter and its circuit with wet hand, otherwise there will be danger of electric shock.
- Do not touch the inverter terminals, otherwise there will be danger of electric shock.

- At power-on, the inverter will perform the security check of the external heavy-current circuit automatically, so at this time please do not touch the terminals U, V and W, or the terminals of motor, otherwise there will be danger of electric shock.



Note

- If parameter identification is required, please pay attention that the rotating motor may injure people, otherwise accident may occur!
- Do not change the factory settings, otherwise the inverter may be damaged!

### 6. Running



Danger

- Do not approach the equipment when restart function is enabled, otherwise there will be danger of injury.
- Do not touch the fan and the discharging resistor to check the temperature, otherwise burning may occur!
- Non-professional person shall not measure the signal of a running inverter, otherwise there will be danger of injury or damaging the inverter!



Note

- Do not let objects fall in a running inverter, otherwise the inverter may be damaged!
- Do not start and stop the inverter by on/off of the contactor, otherwise the inverter may be damaged!





## 7. Maintenance

 Danger
<ul style="list-style-type: none"><li>• Please do not repair or maintain the inverter with power on, otherwise there will be danger of electric shock!</li><li>• Please repair or maintain the inverter after confirming the charge LED turns off, otherwise there may be human injury caused by the residual voltage of the capacitor!</li><li>• Only qualified electrical engineer can repair or maintain the inverter, otherwise there will be danger of human injury or damaging the equipment.</li></ul>

### 1.2 Cautions

#### 1. Check the Insulation of the Motor

When the motor is used for the first time, or reused after storing for a long time, or in regular checkup, the user must check the insulation of the motor to prevent the poor insulation of the windings of motor from damaging the inverter. The motor connection must be divided from the inverter during the insulation check. It is recommended to use a 500V Mega-Ohm-Meter to check and the insulation resistance shall not be less than  $5M\Omega$ .

#### 2. Thermal Protection of Motor

If the rated capacity of the motor selected is not matching that of the inverter, especially when the rated power of the inverter is bigger than that of the motor, make sure to adjust the parameters for motor protection inside the inverter or to install a thermal relay to the motor to guarantee the protection to the motor.

#### 3. Running at Frequency Above Rated Frequency

The output frequency of this inverter is 0~300Hz. Please consider the capability of the mechanical devices when the customer needs the inverter to run at the frequency higher than 50Hz.

#### 4. Motor Heat and Noise

Since the output voltage of the inverter is in PWM wave with some harmonics, the temperature may rise, the noise and vibration may increase compared with the inverter running at main frequency.



## Chapter 1 Safety and Cautions

**5. Pressure-sensitive Device or Capacitor at the Output Side of the Inverter**

Because the inverter outputs PWM wave, the capacitor used for improving power factor and pressure-sensitive resistor used for lightning-proof shouldn't be installed at the output side of the inverter, otherwise the inverter may have transient over-current and may be damaged.

**6. Switches Used at the Input and Output terminal of the Inverter**

If the contactor is required to be installed between the inverter and the power supply, it is prohibited to start or stop the inverter with the contactor. If the user has to use the contactor to start and stop the inverter, the interval between the start and stop shall be less than one hour. Frequent charging and discharging may reduce the life of the capacitor. If the switches like contactors are connected between the output terminal and the motor, make sure to start and stop the inverter when the inverter has no output, otherwise the modules in the inverter may be damaged.

**7. Usage Outside the Range of Rated Voltage**

The MD series inverter shall not be used out of the specified range of operation voltage, otherwise the internal components of the inverter may be damaged. If needed, please use corresponding voltage regulation device to change the voltage.

**8. 3-phase Input Modified Into 2-phase Input**

The modification of MD series inverter from 3-phase input to 2-phase input is not allowed, or fault may occur.

**9. Lightning Strike Protection**

There are lightning protection devices inside the inverter, But the user should install other lightning protection device at the front end of the inverter if lightning strike occurs frequently.

**10. Altitude and Deration**

When the altitude is higher than 1000m, the cooling effect of inverter is deteriorated because of the rarefaction of air, the deration must be used and please consult our company for detailed technical support.

**11. Special Usages**

The user can consult our company if he wants to use another method instead of the recommended

connecting method provided in the manual, such as shared DC bus.

## **12. Cautions for Scrap of Inverter**

The electrolytic capacitors in the main circuits and PCB may explode when they are burned and

poisonous gas may be generated when the plastic parts are burned.

Please dispose the inverter as industrial rubbish.

### **13. About Applicable Motor**

- 1) The standard motor used is the 4-pole squirrel cage asynchronous induction motor. If other kind of motor is used, please be sure to select the applicable inverter according to the rated current of the motor, and please consult us if the user wants the inverter to drive the permanent magnetic synchronized motor.
- 2) The cooling fan of non-variable frequency motor is connected to the rotor in the same bearing, so the cooling effect is weakened if the speed is low, therefore use the variable-frequency motor or install a cooling fan in the overheat condition the motor.
- 3) The inverter has already been configured with the standard parameters for applicable motor, please be sure to modify the default values or perform the motor parameter identification according to the actual conditions, otherwise the operation effect or protection performance may be reduced.
- 4) Short-circuit in the cable or motor may cause the inverter alarm or even damage the inverter. Therefore, please conduct the insulation short-circuit test to the cable and the motor installed for the first time. The short-circuit test shall also be carried out in routine maintenance. Pay attention that the inverter shall be separated from the unit during such test.



## Chapter 2 Product Information

### 2.1 Name Designation Rules

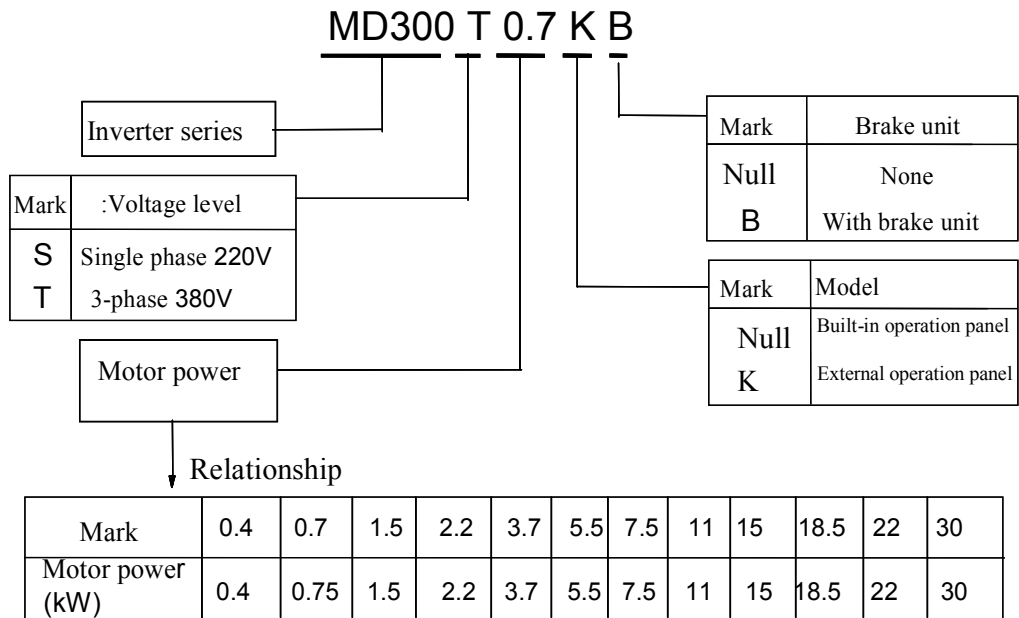

### 2.2 Nameplate

MODLE:	MD320T0.7KB
POWER:	0.75kW
INPUT:	3PH AC380V 3.4A 50HZ/60Hz
OUTPUT:	3PH AC0~380V 2.3A 0~300HZ
S/N:	Bar Code
Shenzhen Inovance Technology Co.,Ltd	





		Chapter 2 Product Information			
<b>2.3 MD300 Series of Inverter</b>					
<b>Model</b>	<b>Input Voltage</b>	<b>Power Capacity (KVA)</b>	<b>Input Current (A)</b>	<b>Output Current (A)</b>	<b>Motor (kW)</b>
MD300S0.4	Single-phase 220V Range: -15%~20%	1.0	5.4	2.3	0.4
MD300S0.7		1.5	8.2	4.0	0.75
MD300S1.5		3.0	14.2	7.0	1.5
MD300S2.2		4.0	23.0	9.6	2.2
MD300T0.7		1.5	3.4	2.1	0.75
MD300T1.5		3.0	5.0	3.8	1.5
MD300T2.2		4.0	5.8	5.1	2.2
MD300T3.7		5.9	10.5	9.0	3.7
MD300T5.5		Three-phase 380V Range: -15%~20%	8.9	14.6	13.0
MD300T7.5	11.0		20.5	17.0	7.5
MD300T11	17.0		26.0	25.0	11.0
MD300T15	21.0		35.0	32.0	15.0
MD300T18.5	24.0		38.5	37.0	18.5
MD300T22	30.0		46.5	45.0	22.0
MD300T30		40.0	62.0	60.0	30.0



Chapter 2		Product Information	
2.4 Technical Specification			
		<b>Item</b>	<b>Specification</b>
		Maximum output frequency	300Hz
		Carrier frequency	0.5K~16K (Hz); Carrier frequency can be adjusted automatically according to the load characteristic.
		Input frequency resolution	Digital setting: 0.01Hz Analog setting: Maximum frequency×0.1%
		Control mode	Open loop vector control (SVC), vector control (VC), V/F control
		Start torque	0.5Hz/150% (SVC)
		Speed control range	1: 100 (SVC)
		Speed accuracy	± 0.5% (SVC)
		Overload capability	150% rated current for 60s; 180% rated current for 1s
		Torque boost	Auto Torque boost; Manual Torque boost 0.1%~30.0%
		V/F curve	2 modes: Line, square v/f curve
	Personalized function		DC brake
		Jog control	Jog frequency range: 0.20Hz~50.00Hz; Jog Acc/Dec time: 0.0~3000.0s
		Self-checking of external equipment upon Power-on	Check the security of external equipment upon power-on such as earthing and short circuit.
		Shared DC bus	Several motors can share one DC bus.
Input/output characteristic		MF.K key	Programmable key: selection command channel, run forward/reverse/programmable jog operation
		Command channel	Two channels to issue the command: operation panel, control terminal, serial port.
		Frequency source	6 frequency sources: digital frequency reference, analog voltage reference, analog current reference, pulse reference. These frequency sources can be selected through different methods.
	Auxiliary frequency sources	Fine tuning and synthesis of auxiliary frequency can be implemented flexibly.  Input terminal	

Four digital input terminals and one of them can input high speed pulse.

Two analog input terminals, one can be inputted voltage and the other can be inputted voltage or current.

Chapter 2		Product Information
	Item	Specification
	Output terminal	One digital output terminal One relay output terminal One analog output terminal, can realize the output of setting frequency and output frequency, etc.
Display and keypad	LED display Parameter copying	Be able to display multiple parameters such as setting frequency, output frequency, output voltage and current, etc. Quick copying of parameters can be realized
Protection function		Power-on motor short circuit test, input/output phase failure protection, Over current protection; Over voltage protection; Under voltage protection; Over heat protection; overload protection
Applicable Situation		Indoor in which there is no direct sunlight, dust, erosive gas, combustible gas, oil smoke, water vapor, dripping, salt, etc.
Environment	Altitude	Lower than 1.000 meters
	Ambient temperature	-10°C~+40°C (ambient temperature is within 40°C~50°C, deration is required)
	Humidity	Less than 95%RH, without condensation
	Vibration	Less than 5.9m/s <sup>2</sup> (0.6g)
	Storage temperature	-20°C~+60°C

## 2.5 Product Appearance and Dimension of Installation Holes

### 1. Product Appearance:

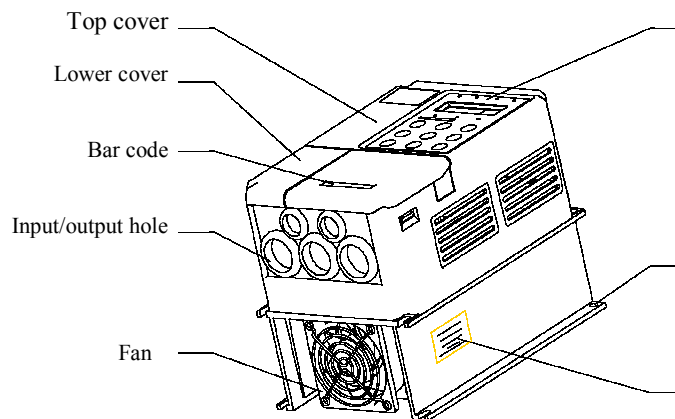

Fig.2-1 Product Appearance

Operation panel

Bottom installation holes

Nameplate

Chapter 2 Product Information

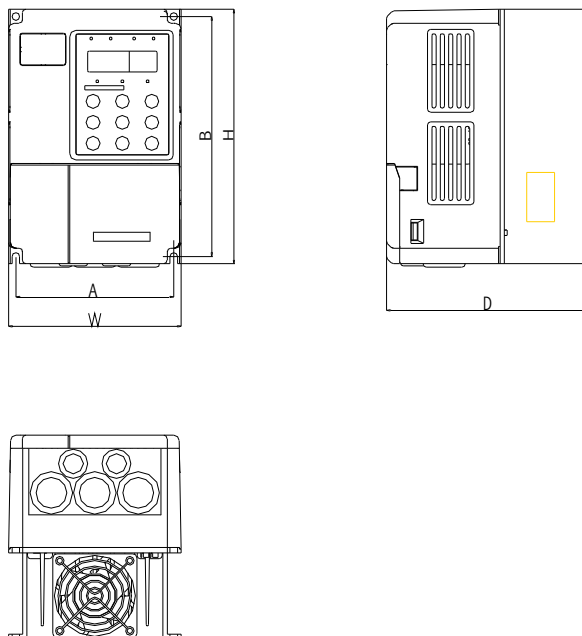

Fig.2-2 Inverter Appearance and Dimension of Installation Holes

**Dimensions of keypad**



Fig.2-3 Keypad Appearance and Dimension of Installation Holes

**Installation Dimensions of keypad**

Fig.2-4 Keypad Installation Dimensions

**2. Dimension of Installation Holes**

Inverter Model		A (mm)	B (mm)	H (mm)	W (mm)	D (mm)	Hole diameter (mm)	Weight (kg)
MD300S0.4G	Single-phase 220V	113	172	182	123	145	φ 5.4	2.2
MD300S0.7G								2.2
MD300S1.5G								2.2
MD300S2.2G								2.2
MD300T0.7G	3-phase 380V	148	236	246	158	165	φ 5.4	2.2
MD300T1.5G								2.2
MD300T2.2G								2.2
MD300T3.7G								4
MD300T5.5G								4
MD300T7.5G								10
MD300T11G								10
MD300T15G	10							
MD300T18.5G	235	447	460	285	220	φ 6.5	24	
MD300T22G							24	
MD300T30G							24	

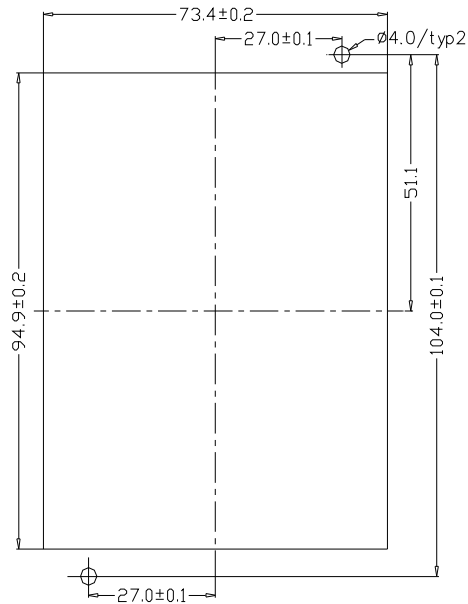

Chapter 2 Product Information			
<b>2.6 Optional Parts</b>			
Name	Model	Function	Remark
Built-in brake unit	Product model has a suffix of "B"	Single phase: 0.4-2.2kW built-in brake unit optional; 3-phase: 0.75-2.2kW; 18.5-30kW built-in brake unit optional.	3-phase: 3.7-15kW built-in brake unit (Standard configuration)
Injection molding machine card	MD30IN	Change injection molding machine 0~1A or 0~24V to 0~10V and output without insulation	Special for energy saving of injection molding machine
External LED keypad	MDKE	External LED display and keypad	MD series of general-purpose RJ45 interface
Parameter copy interface	MDCP	Parameter copy	MD series of general-purpose RJ45 interface
Prolonged cable	MDCAB	Standard 8-core network cable that can be connected to MDKE and MDCP	Four specifications: 1m, 3m, 5m and 10m

Refer to Fig.2-5 for the installation of optional parts and refer to the instructions on the optional parts on the detailed function and usage of the optional parts. If the user needs the above optional part, please note this when ordering.

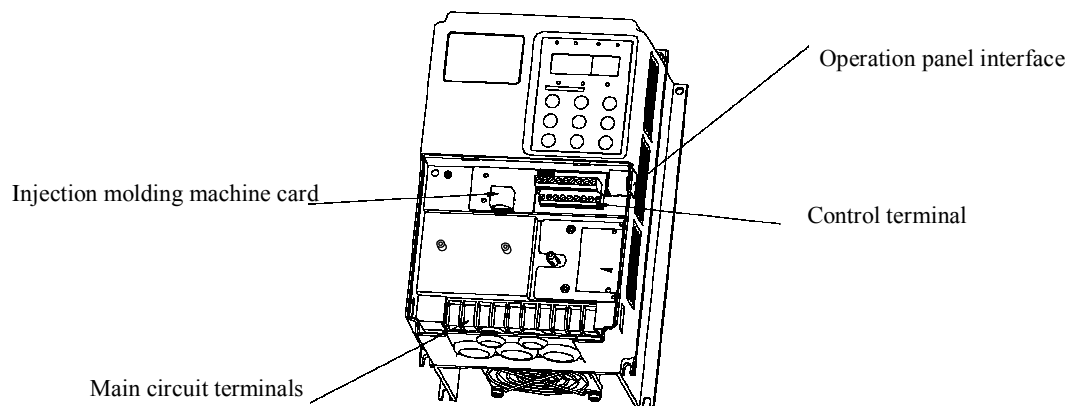

Fig.2-5 Installation of optional parts

## 2.7 Daily Maintenance of Inverter

### 1. Daily Maintenance

Since the influence of ambient temperature, humidity, dust, and vibration, the components in inverter

may become aging and wearing, which will give rise to the occurrence of potential faults and reduce the life of inverter. Therefore, it is quite necessary to perform routine and periodic maintenance to the inverter.

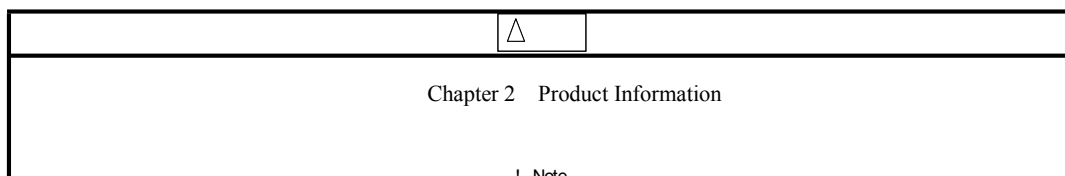

The filter capacitor still has high voltage after the power supply to the inverter is switched off, so do not maintain or repair the inverter until the bus voltage measured by a multi-meter is below 36V.

Daily checking items:

- 1) Check if there is any abnormal noise during the running of motor;
- 2) Check if there is any vibration of motor;
- 3) Check if the installation environment of inverter changes;
- 4) Check if the cooling fan of inverter works normally;
- 5) Check if the inverter is over heated

Daily cleaning:

- Keep the inverter in a clean status.
- Clear the dust from the inverter and prevent the dust especially the metal powder from entering the inverter.
- Clear the oil dirt in the cooling fan of the inverter.

## 2. Periodical Checking

Periodically check the places that are hardly checked during the running.

Checking items:

- 1) Check the ventilation channels and clean them periodically
- 2) Check if the screws are loose
- 3) Check if the inverter is rusted
- 4) Check if the input/output terminals has burning mark
- 5) Check the insulating in main circuit

Note: Insulation test (use 500V Mega-Ohm-Meter) should be done separately after disconnecting the input power cables from the inverter; or else, the inverter will be damaged. Do not use the Mega-Ohm-Meter to test the insulation of control circuits. Dielectric strength test had been done at factory. Therefore, user need not do this test again.

## 3. Replacement of Wearing Parts

The wearing parts of inverter mainly include the cooling fan and filtering electrolytic capacitor. Their lifetime is closely related to the operating environment and maintenance. Generally their lives are:

## Chapter 2 Product Information

Component	Life
Fan	2~3 years
Electrolytic capacitor	4~5 years

User should determine when to replace them according to their work time.

#### 1) Cooling fan

Possible damage causes: shaft bearing attrition and blade aging.

Judging criteria: no crack on fan blade, and no abnormal vibration noise at start.

#### 2) Filtering electrolytic capacitor

Possible damage causes: high ambient temperature, big pulsating current due to frequent load fluctuation, electrolyte aging.

Judging criteria: no liquid leak, no protrusion of safety valve, electrostatic capacitance measurement, and insulation resistance measurement.

### 4. Storage

The following points must be followed in inverter storage:

- 1) It is recommended to store the inverter in its original packing box.
- 2) Long-term storage will cause deterioration of electrolytic capacitor. Therefore, inverters long time not in service must be powered within 2 years for test purpose, at least for 5 hours; in the test, the input voltage must be boosted gradually with voltage regulator to the rated value.

### 2.8 Warranty

The warranty is only confined to the inverter.

- 1) We provide warranty for a period of 18 months (start from the delivery date with reference to the bar code on the inverter) for faults and damages under the condition of proper use. After 18 months, maintenance will be fairly charged.
- 2) Within the 18-month warranty period, maintenance will be fairly charged for the following inverter



damages:

- a. Damage resulting from operations not in compliance with User Manual;
- b. Damage resulting from fire, flood, abnormal mains voltage, and so on;

## Chapter 2 Product Information

- c. Damage resulting from use of functions outside specifications;

Service is charged according to the actual expenses, however, if there is contract, priority is given to the contract.

## 2.9 Model Selection

Three control modes: Common V/F, SVC and VC

The user must be familiar with the technical requirements for adjustable speed induction motor drives , application and load characteristics before selecting the inverters, and consider the motor, output voltage and rated output current so as to select the correct model and operation mode.

The basic rule: Motor's rated load current cannot exceed the rated current of the inverter. Generally the motor shall be selected according to the motor capacity. Compare the motor's rated current and the inverter's rated current when selecting. Inverter's overload capability is very important for the start and brake processes. Please select the inverter with higher overload capability if short time overload condition may occur or the application requires higher speed accuracy.

The load like blower and pump has a low requirement for overload capability. Since the load torque is proportional to the square of the speed, the load is light at low speed (except Ruth blower), also the load has a low requirement for the speed accuracy, the square V/F control mode is suitable for these loads.

Constant torque load: Most of the load has such characteristics of constant torque and the load has low requirement for speed accuracy and dynamic performance. The typical loads are: extrusion machine, blender, conveyor belt, transportation electrical vehicle and crane. Multi-speed V/F control mode is suitable for these loads.

Certain dynamic and static index requirements of the controlled objects: This kind of load generally requires hard mechanical performance when running at low speed to meet the requirements of dynamic and static index for the control system in the production process. The open loop vector control mode may be selected.

## 2.10 Selecting Braking Units



Chapter 2 Product Information			
<b>Table of Selecting Braking Units (brake torque 100%)</b>			
Inverter model	Brake resistor	Brake unit	Remark
MD300S0.4	200Ω/80W		
MD300S0.7	150Ω/100W		
MD300S1.5	100Ω/300W		
MD300S2.2	70Ω/400W		
MD300T0.7	300Ω/300W		
MD300T1.5	200Ω/300W	Built in, optional	Add "B" to the inverter model
MD300T2.2	220Ω/660W		
MD300T3.7	130Ω/1100W		
MD300T5.5	90Ω/1600W		
MD300T7.5	65Ω/2500W		
MD300T11	43Ω/3500W	Built in, standard	No special remarks
MD300T15	42Ω/4500W		
MD300T18.5	25Ω/5500W		
MD300T22	22Ω/6500W	Built in, optional	Add "B" to the inverter model
MD300T30	16Ω/9000W		



## Chapter 3 Mechanical and Electrical Installation

### 3.1 Mechanical Installation

#### 1. Installation Environment

- 1) Ambient temperature: Ambient temperature influences the inverter life greatly, so it should be within the range of  $-10^{\circ}\text{C}\sim 50^{\circ}\text{C}$ .
- 2) Mount the inverter in a flame retardant surface and the clearance around the inverter shall be enough because the inverter will generate lots of heat during running, besides mount the inverter on the base vertically with screws.
- 3) Mount in the location where vibration is less than 0.6G; the inverter shall be far away from impacting lathe.
- 4) Please do not install the inverter in the place with direct sunlight, high humidity and water.
- 5) Mount the inverter in the location free of corrosive gas, explosive gas or combustible gas.
- 6) Mount the inverter in the location free of oil dirt, dust, and metal powder.

#### 2. Installation Location

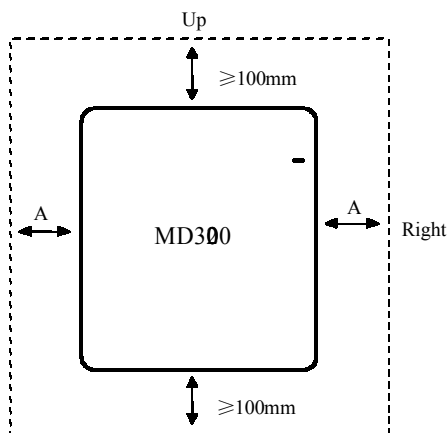

Note: No need to consider the dimension A for inverter of 22kW or below.  
A shall be bigger than 50mm for the inverter of 22kW or above

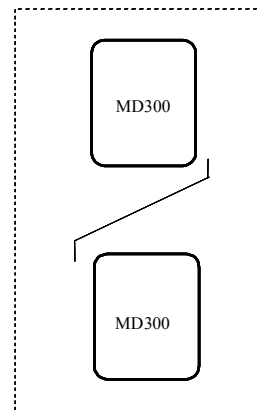

Installation of single inverter

Note: Install an airflow-guidance plate  
for the up and down installation of inverters.

Up and down installation of inverters

Fig.3-1 MD Series Inverter Installation Location

## Chapter 3 Mechanical and Electrical Installation

The user shall focus on the heat dissipation issues when installing the inverter, and pay attention to the following points:

- 1) Install the inverter vertically so that the heat may be expelled from the top, but do not install the inverter upside down. When two Variable Speed Drives are mounted up and down, an air flow diverting plate should be fixed in between as shown in Fig. 3-1.
- 2) Installation space is shown in Fig.3-1 so as to ensure the heat dissipation space, but consider the heat dissipation of other components when placing the inverter.
- 3) The installation bracket must be flame retardant.
- 4) Install the heat sink outside of the cabinet if the inverter is installed in the area with metal powder. And in this case, the space inside the sealing cabinet shall be big enough.

### 3. Install and Remove the Bottom Cover

The MD series of inverter of 15kW or below uses plastic covers. Refer to Fig.3-2 for removing the bottom cover, the cover can be removed by using a tool to push the hook inward.

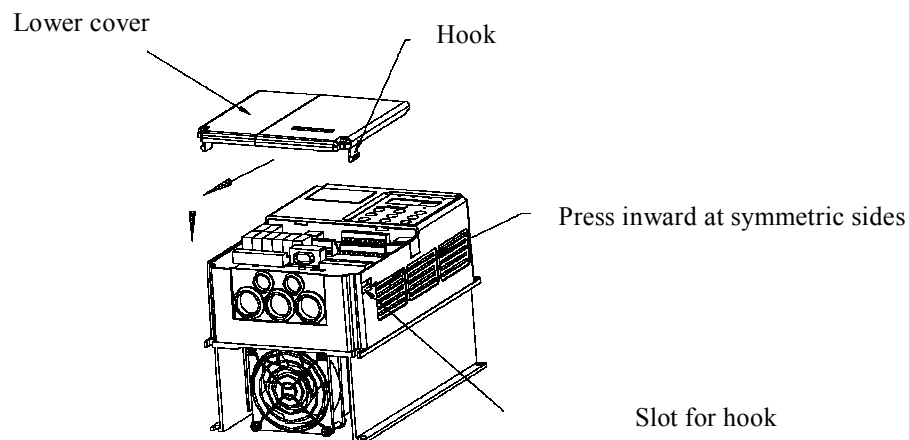

Fig.3-2 Remove the bottom cover

The MD series of inverter of 18.5KW or below uses metal covers. Refer to Fig 3-3 for removing the bottom cover, the cover can be removed by removing the screws of the cover.

! Danger



When removing the bottom cover, be sure to avoid the human injury caused by the falling of the bottom cover!

## Chapter 3 Mechanical and Electrical Installation

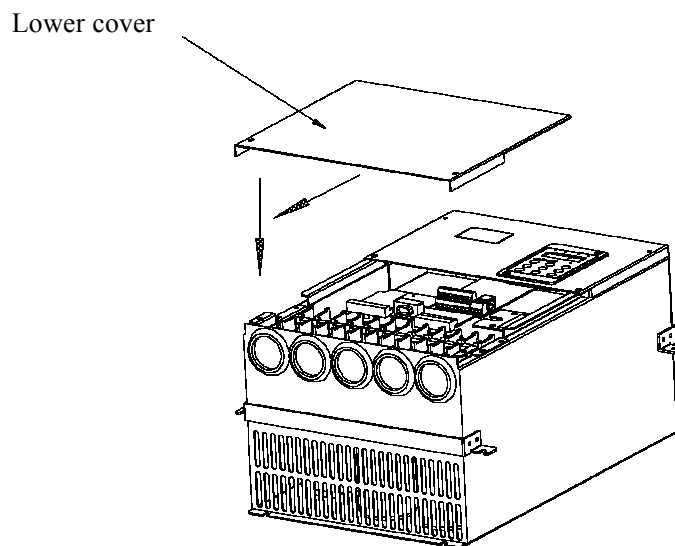

Fig.3-3 Remove the metal bottom cover

### 3.2 Electrical Installation

#### 1. Model Selection of External Devices

Inverter Model	Circuit breaker (MCCB) (A)	Contactor (A)	Input cables (mm <sup>2</sup> )	Output cables (mm <sup>2</sup> )	Control cables (mm <sup>2</sup> )	Grounding cables (mm <sup>2</sup> )
MD300S0.4	16	10	2.5	2.5	1	2.5
MD300S0.7	16	10	2.5	2.5	1	2.5
MD300S1.5	20	16	4	2.5	1	2.5
MD300S2.2	32	20	6	4	1	2.5
MD300T0.7	10	10	2.5	2.5	1	2.5
MD300T1.5	16	10	2.5	2.5	1	2.5
MD300T2.2	16	10	2.5	2.5	1	2.5
MD300T3.7	25	16	4	4	1	2.5
MD300T5.5	32	25	6	6	1	4
MD300T7.5	40	32	6	6	1	4
MD300T11	63	40	6	6	1	4
MD300T15	63	40	6	6	1	4
MD300T18.5	100	63	10	10	1	4
MD300T22	100	63	10	10	1	4
MD300T30	125	100	16	16	1	4



Chapter 3 Mechanical and Electrical Installation		
<b>2. Using of External Devices</b>		
<b>Device</b>	<b>Installation location</b>	<b>Function</b>
Air switch	Front-end of input circuit	Switch off the power supply when over current occurs on the downstream equipment.
Contactator	Connected between the circuit breaker and the inverter	Switch on/off the inverter, but avoid switching on/off the inverter frequently by directly using the contactor (less than 2 times in one minute).
AC input reactor	Inverter input	1) Improving the input power factor, 2) Eliminate the high frequency harmonics in the input and prevent the voltage distortion from damaging other equipment 3) Eliminate the input current unbalance due to the unbalance of the input three phases
DC reactor	Use DC reactor for the MD series of inverter of 7.5kw or above  Connected between the inverter	1) Improving the input power factor 2) Improve the efficiency and reliability of inverter 3) Eliminate the high frequency harmonics in the input to reduce the conduction and radiation The inverter output voltage usually has high frequency harmonics. The distributed capacitance will be big if the inverter is far away from the motor, therefore resonance may occur, which may result in:
AC output reactor	output and the motor and the reactor shall be as close to the inverter as possible.	1) Damaging the motor insulation and damaging motor that has been in this status for a long time 2) Big leakage current and make the inverter enter into protective status frequently. If the distance between the inverter and the motor is longer than 100m, it is recommended to install the AC output reactor.

### 3. Wiring Mode



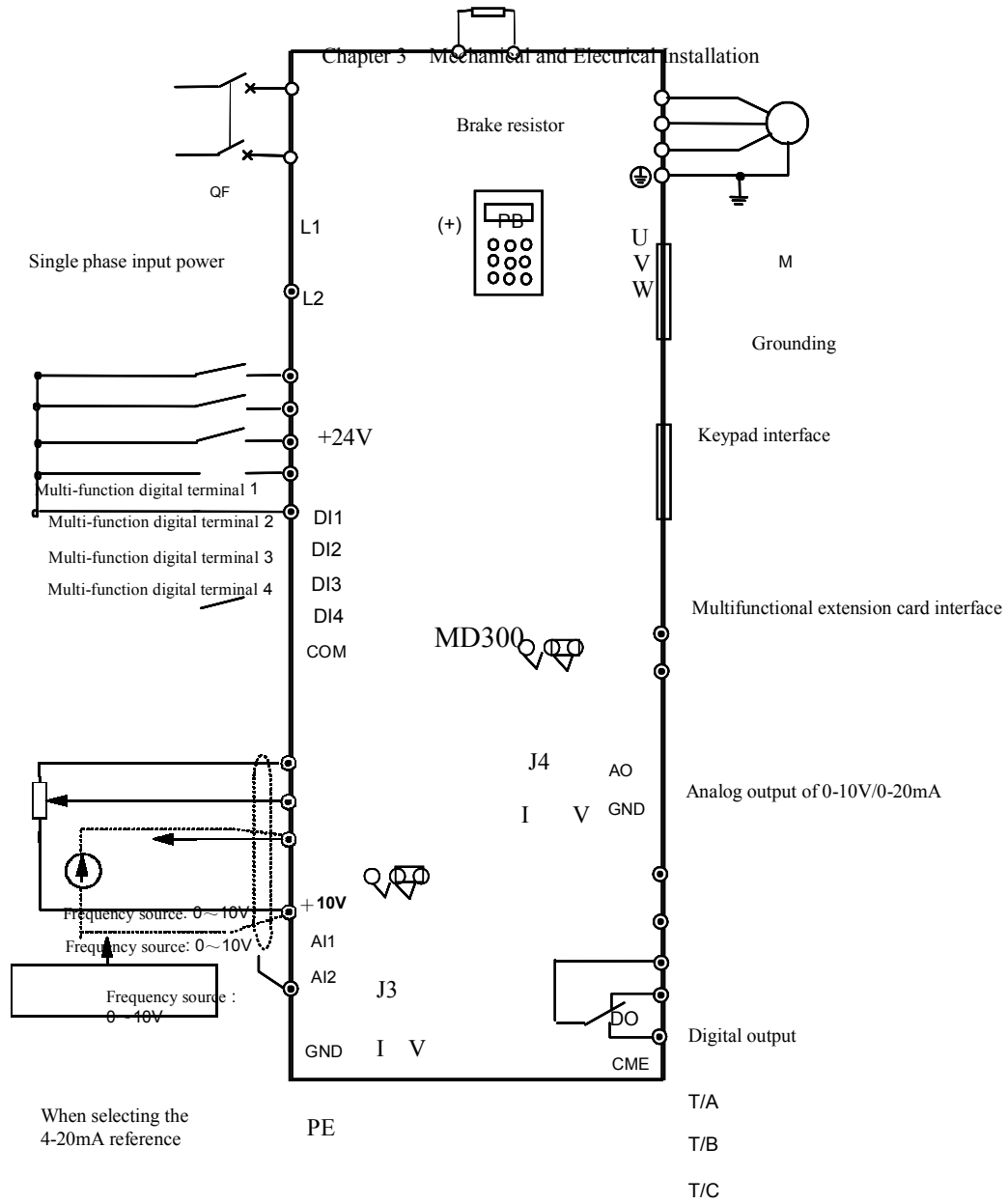

Fig.3-4 Wiring Mode of Single Phase 220V Inverter

**Note:** This figure is suitable for MD300S0.4, MD300S0.7, MD300S1.5 and MD300S2.2 inverters.



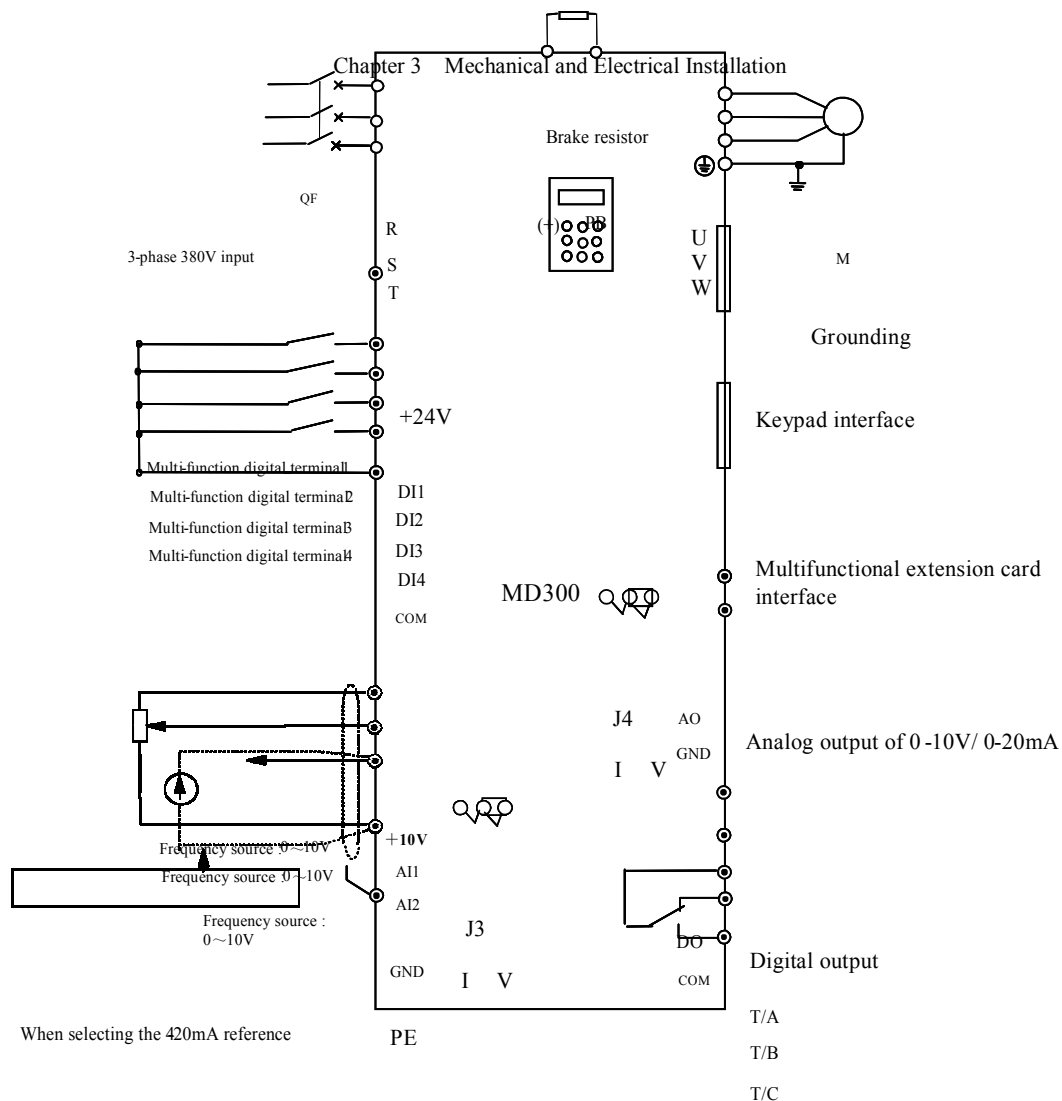



Fig.3-5 Wiring Mode of Three Phase 380V Inverter

**Note:** This figure is suitable for MD300T0.7~MD300T30 series inverters.





#### 4. Main Circuit Terminals and Wiring

 Danger
<ul style="list-style-type: none"> <li>• Wiring can only be done after the mains input is cut off, otherwise there will be danger of electric shock!</li> <li>• Only qualified and trained engineer can perform the wiring, otherwise there will be danger of electric shock!</li> <li>• Grounding cable must be grounded, otherwise there will be danger of electric shock or fire!</li> </ul>

 Notes
<ul style="list-style-type: none"> <li>• Please confirm the mains voltage level is same with that of the inverter, otherwise the inverter may be damaged!</li> <li>• Make sure the ratings of the driven motor are in compliance with the inverter, otherwise the motor may be damaged or the inverter may be in protection status!</li> <li>• Do not confuse the input terminals with the output terminals (U, V, W), otherwise there will be danger of damaging the inverter!</li> <li>• Brake resistor cannot be connected between the DC bus terminals (+) and (-), otherwise fire may occur!</li> </ul>

##### 1) Main Circuit Terminals of Single-phase Inverter

Terminals	Name	Remark
L1, L2	Single phase power input terminal	Connect single phase AC220V
(+), (-)	Positive and negative terminals of DC bus	Shared DC bus input
(+), PB	Terminal for brake resistor	Connect brake resistor
U, V, W	Inverter output terminal	Connect 3-phase motor
	Terminal for grounding	Grounding terminal

##### 2) Main Circuit Terminals of Three-phase Inverter

Terminals	Name	Remark
R, S, T	3-phase power input terminal	Connect 3-phase AC380V
(+), (-)	Positive and negative terminals of DC bus	Shared DC bus input, for inverter above 37kW, they are for brake unit
(+), PB	Terminal for brake resistor	For inverter below 30kW, they are for brake resistor
U, V, W	Inverter output terminal	Connect 3-phase motor
	Terminal for grounding	Grounding terminal

3) Notes on Wiring

A. Input power supply L1 and L2 or R, S and T:

There is no phase-ration requirement for the input of inverter.

## Chapter 3 Mechanical and Electrical Installation

## B. DC bus (+) and (-) terminals:

Pay attention that the DC bus terminals (+) and (-) still have voltage after power off, and the user can only touch the terminals after the CHARGE LED turns off and the voltage is below 36V, otherwise there is a danger of electric shock.

When selecting the brake unit for the inverter above 37kW, pay attention that the polarity of (+) and (-) cannot be reverse, otherwise the inverter may burn or be damaged. The cable length of brake unit shall be less than 10m and twisted pair cables shall be used.

Do not connect the brake resistor directly to the DC bus, otherwise the inverter may burn or be damaged.

## C. Brake resistor terminals of (+) and PB:

The brake resistor terminal is effective only for the inverter of 30kW or below and has a built-in brake unit. Select the recommended resistor with the cable length of less than 5m, otherwise the inverter may burn or be damaged.

## D. Inverter output U, V and W:

Inverter output terminals cannot connect to capacitors or surge snub devices, otherwise the inverter may be in protective status or damaged.

If the cables between the motor and the inverter are too long, electrical resonance may occur due to the distributed capacitance, which may result in damaging the motor insulation or big leakage current, so if the cable length is longer than 100m, AC reactor must be installed.

## E. Grounding Terminal:

Grounding Terminal must be connected to earth reliably and the grounding resistance shall be less than 5Ω, otherwise the equipment may work abnormally or be damaged. Do not share the PE and neutral line of the mains supply.

**5. Control Terminals and Wiring**

## 1) Layout of Control Terminals

+10V	A11	A12	GMD	AO	D11	D12	D13	D14	COM	DO	+24V	T/A	T/B	T/C
------	-----	-----	-----	----	-----	-----	-----	-----	-----	----	------	-----	-----	-----



Chapter 3 Mechanical and Electrical Installation			
Type	Terminal	Terminal name	Function
2) Function of Control Terminals			
Power Supply	+10V-GND	External +10V power supply	+10V power supply outwards, Maximum output current: 10mA Usually used as the external potentiometer working power supply, the resistance value of the potentiometer: 1~5KΩ
	+24-COM	External +24V power supply	+24V power supply outwards, usually used as the power supply for the digital input/output terminal and the external sensor Maximal output current: 200mA
Analog Input	A11-GND	Analog input terminal 1	1. Input voltage range: DC 0~10V 2. Input resistance: 100KΩ
			1. Input range: DC 0~10V/4~20mA, selected and decided by the jumping wire J3 on the control board
	A12-GND	Analog input terminal 2	2. Input resistance: Voltage input: 100KΩ Current input: 500Ω
Functional Digital input terminal	DI1	Digital input 1	1. Input resistance: 3.3KΩ
	DI2	Digital input 2	2. Voltage range of level input: 9~30V
	DI3	Digital input 3	Besides the characteristics of DI1~DI3, it can also be used as high-speed pulse input channel, with a maximum input frequency of 50KHz.
	DI4	High-speed pulse input terminal	
Analog output	AO-GND	Analog output 1	Select voltage or current output through the jumper J4.
Digital output	DO-COM	Digital output 1	Output voltage range: 0~24 Output current range: 0~50mA

Relay output	T/A-T/B	Normally close terminal	Contacts drive capability: AC250V, 3A, COSØ =0.4 DC30V, 1A
	T/A-T/C	Normally open terminal	

### 3) Notes on Control Terminals:

#### A) Analog input terminal:

Since the weak analog voltage signal is easily disturbed by external disturbance source, shielded cable shall be used and the cable shall be as short as possible and the length shall not exceed 20m, as shown in the figure 3-6. If the analog signal is severely disturbed, filter capacitor or ferrite core shall be installed at the analog signal source as shown in the Fig. 3-7:



## Chapter 3 Mechanical and Electrical Installation

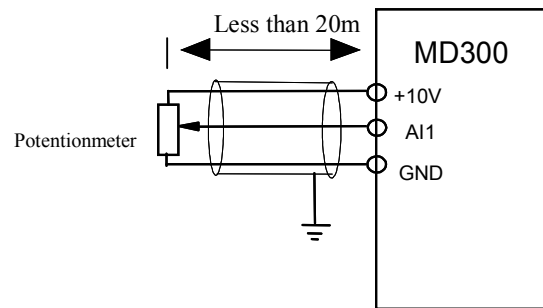

Fig. 3 -6 Analog Input Terminal of MD Series Inverter

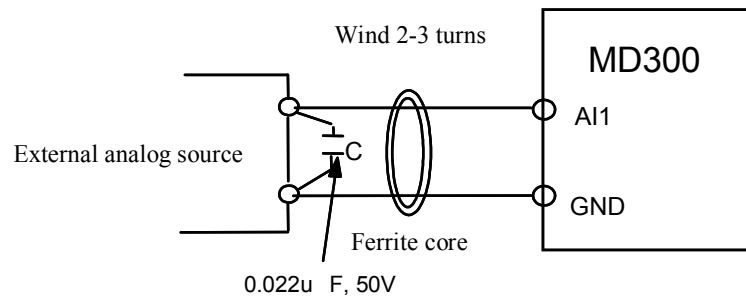

Fig. 3 -7 Analog Input Terminal With Filter devices

## B) Digital input terminal:

The inverter judges the ON/OFF status of these terminals by receiving the digital signal. Hence, all the external contactors are those with high reliability of weak signal conduction.

If the open collector is employed to provide ON/OFF signal for the inverter digital input terminal, then it shall be considered that there is error operation caused by power supply interference.

It is recommended to use contact control mode.

## C) Digital Output terminal:

When digital output terminal drives a relay, the coil of the relay shall be installed a snubbing diode, otherwise the DC 24V power supply may be damaged.

**Note:** Pay attention to the polarity of the diode as shown in the figure 3-8. Otherwise if the digital output terminal has output, the DC24V power supply will be damaged.





## Chapter 3 Mechanical and Electrical Installation

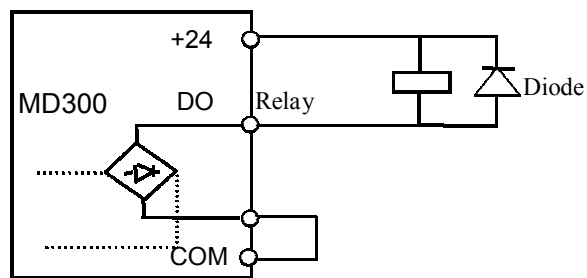

Fig. 3 -8 Digital Input Terminal of MD Series Inverter

## 6. EMC Issues

### 1. Influence of Harmonics

- 1) The high frequency harmonics of mains supply will influence the rectifying circuit of the inverter. The harmonics will heat the rectifying circuit and even damage the circuit. So, it is recommended to install the filtering device in the environment where the power quality is poor.
- 2) Since the inverter output has high frequency harmonics, the output cannot be installed with capacitor or surge suppressing devices because the capacitor and surge suppressing device may resonate the circuit and damage the equipment.

### 2. EMI

- 1) Two kinds of EMI, one is the EMI around the inverter and disturbs the inverter. This kind of EMI is weak, besides the inverter has been designed with strong immunity. Another is the EMI from the inverter that may influence the equipment around the inverter. The inverter itself is a disturbance source because it outputs PWM wave through high carrier frequency, so solving the EMI issue is mainly to reduce the EMI of inverter.

Methods:

- A) Inverter and other equipment shall be well grounded and the grounding resistance shall be less than 10ohm.
- B) Inverter's power cables shall be vertical instead of parallel with the control cables.
- C) For the application with strong disturbance, the power cables from the motor to the inverter shall be shielded and the shielding layer shall be grounded.
- D) The cables of disturbed equipment shall be twisted shielded cables and the shielding layer shall be

grounded.

- 2) Reducing the disturbance to the inverter from other equipment

The relay, contactor or electronic-magnetic braking device will disturb the inverter.

## Chapter 3 Mechanical and Electrical Installation

Take the following actions to solve this issue:

- A) Install surge suppressing devices to the disturbing device
  - B) Install filter to the input of the inverter
  - C) Inverter's control cables shall be shielded and the shielding layer shall be grounded
- 3) Method to reduce the disturbance from the inverter to the equipment

Two kinds of noises, one is the radiation from the inverter itself, and another is the radiation from the cable between the inverter and the motor. These two kinds of radiations induce the cables of the equipment and make the equipment work abnormally. Following method can be used:

- A) If the measuring meters, radio equipment and sensors and their signal cables are installed in a cabinet together with the drive, these equipment cables will be easily disturbed. Take the actions below to solve the problem: The equipment and the signal cables should be as far away from the inverter as possible; Signal cables and power cables shall not be routed in parallel or bound together; The signal and power cables should be shielded; Install radio noise filter and linear noise filter at the input and output sides of the inverter
- B) If the external equipment shares a same AC supply with the inverter, and the above cannot eliminate the disturbance, then the user should install a linear filter or a radio noise filter.
- C) Ground the external equipment and eliminate the disturbance of the leakage current from the inverter's grounding cable.

### 3. Leakage current

The inverter has two kinds of leakage current, one is the grounding leakage current and another is the leakage current between the lines:

- 1) Grounding leakage current:

The distributed capacitance exists between the cables and the ground, and the bigger the capacitance and the bigger the leakage current, so the motor cables should be as short as possible. Besides, the bigger the carrier frequency is, the bigger the leakage current is, so the user can also reduce the carrier wave frequency, but the motor noise may increase. Installing reactor can also reduce the leakage current. The leakage current is increased with the increase of the circuit current, so the leakage current is big if the motor power is big.

2) Leakage current between lines:

The distributed capacitance exists in the inverter's output cables, and resonance may occur if high frequency harmonics exist in the current, thus the leakage current occurs, which may result in the wrong

Chapter 3 Mechanical and Electrical Installation

action of relay.

The method to solve this issue is to reduce the carrier frequency or install the output reactor. It is recommended to use inverter's protection function instead of a thermal relay to protect the motor before using the inverter.



## Chapter 4 Operation and Display

### 4.1 Operation and Display Interface

Use the operation panel to change the parameters of the inverter, monitor the working status of the inverter and control the running (start and stop) of the inverter. The panel and its functions are shown in Fig. 4-1:

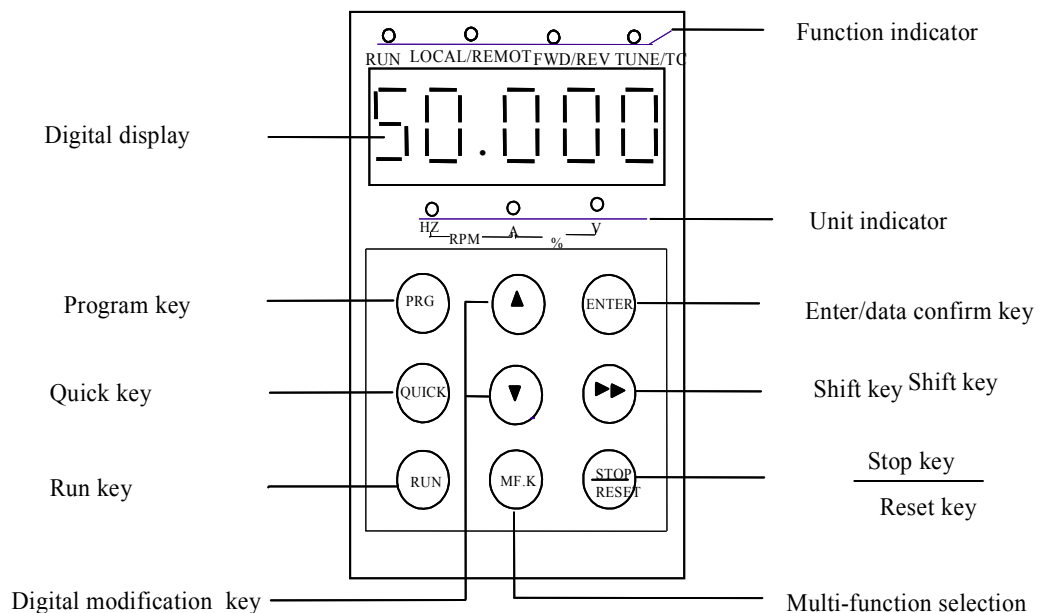

Fig. 4-1 Operation Panel Schematic Diagram

#### 1) Explanations on the indicators:

**RUN:** If it is OFF, it indicates that the inverter is in stop status. If it is ON, it indicates that the inverter is in running status.

**LOCAL/REMOT:** Keypad, terminal and remote operation (communication control) indicator. If it is OFF, it indicates that the inverter is in keypad operation and control status. If it is ON, it indicates that the inverter is in terminal operation status. If it is flashing, it indicates that the inverter is in remote operation and control status.

**FWD/REV:** It is the forward/reverse running indicator. If it is ON, it indicates that the inverter is in



forward running status. If it is OFF, it indicates that the inverter is in reverse running status.

TUNE/TC: It is the tuning and control mode indicator. If it is ON, it indicates that the inverter is in torque control status. If it is OFF, it indicates that the inverter is in speed control status. If it is flashing, it indicates the inverter is in the process of motor tuning.

## Chapter 4 Operation and Display

## 2) Unit Indicators Description

Hz: Frequency unit

A: Current unit

V: Voltage unit

RPM: Rotation speed unit

%: Percentage

## 3) Digital display area

5-bit LED can display frequency setting, output frequency, various monitor data alarm code, etc.

## 4) Function Description of Keys

Table 4-1 Key Functions

Keys	Name	Function
PRG	Program key	Entering or exiting the first-level menu
ENTER	Confirm	Enter the menu screen level by level and confirm the parameter settings.
^	Up	Increase of data or function code
∨	Down	Decrease of data or function code
»	Shift	It can select the displaying parameters circularly on the stop displaying interface and the running displaying interface. It can also select the modification bit of the parameters when modifying the parameters.
RUN	RUN	In the keypad operation mode, it is for running and operating the inverter.
STOP/R ESET	STOP/RESET	The key is for stopping the running when the inverter is running state, and for resetting in the faulty status. The function of the key is restricted by F7-02.
MF.K	Multi-function selection	F6-11=0, No function. F6-11=1, Switch between the local operation and the remote operation. F6-11=2, Switch between the forward rotation and the reverse rotation. F6-11=3, Forward jog operation. Refer to F6-11 for details

## 4.2 Modify and Check the Function Codes

MD300 series inverter's operation panel uses 3-level menu to conduct parameter settings.

3-level menu: function parameter group (first level) function code (second level)→setting of function

code (third level). Operation procedure is shown in Fig. 4-2.

## Chapter 4 Operation and Display

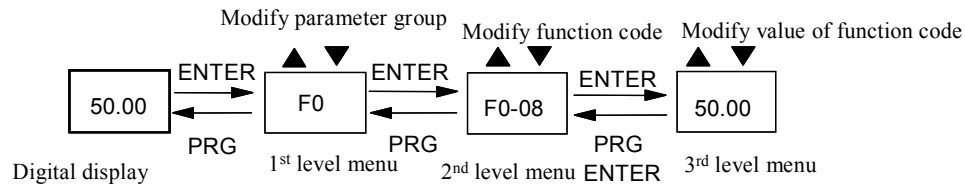

Fig. 4-2 Operation Procedures for 3-level Menu

**Note:** When operating 3-level menu, pressing **PRG** or **ENTER** can return to second level menu. The difference is: pressing **ENTER** will save the parameters and return to second level menu and then shift to the next function code, while pressing **PRG** will return to second level menu without saving the parameters.

Example: Change the setting of F2-05 from 10.00Hz to 15.00Hz. (Bold means flash bit.)

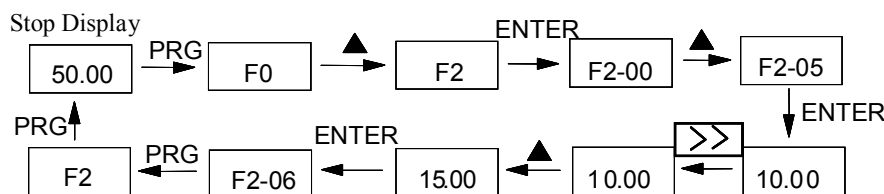

Fig. 4-3 Example for Parameter Changing

In third level menu, if the parameter has no flash bit, it means the function code cannot be changed and the possible reasons are:

- 1) This parameter of this function code cannot be changed, such as the actually detected parameter and running record parameter.
- 2) This function code cannot be changed in operating status and can only be changed when the inverter is stopped.

### 4.3 How to View Status Parameters

When MD300 inverter is in the stop or running status, several status parameter of the inverter can be displayed on the LED nixie tube. Pressing the key **▶▶** can display the stop or running status parameters in sequence. There are five stop status parameters to be displayed in the stop status, namely, setting frequency, bus voltage, DI input status, analog input AI1 voltage and analog input AI2 voltage.

MD300 inverter has seven running status parameters to be displayed in the running status, namely, running frequency, bus voltage, output voltage, output current, DI input status, analog input AI1 voltage,

and analog input AI2 voltage.

Of which, the terminal status (displayed in decimal number) is indicated in the unit of bit, which is described as follows:

## Chapter 4 Operation and Display

BIT 0=1, indicating that DI1 input is valid.

BIT 1=1, indicating that DI2 input is valid.

BIT 2=1, indicating that DI3 input is valid.

BIT 3=1, indicating that DI4 input is valid.

BIT4 and BIT5 are reserved.

BIT6=1, indicating that RELAY output is valid.

BIT7=1, indicating that DO output is valid.

If the inverter is powered on again after power-off, the parameters displayed are defaulted as those selected before the power-off.

#### 4.4 Password Setting

This inverter provides password protection for users. When FP-00 is set to non zero, that is the user password, and the password protection function is valid once exiting the function code editing status. If the user presses **PRG** again, the inverter shall display “-----”, and the user can only enter the menu after inputting the user password. Otherwise, the user cannot enter.

If the user wants to cancel the password protection function, enter after inputting the password and set FP-00 as 0. The protection function of user password to the parameters in quick menu is dependent on the status of F7-03, but it cannot protect the parameter values.

#### 4.5 Auto Tuning of Motor Parameters

Before running the inverter that has selected the vector control mode, accurate motor nameplate parameters must be input to the inverter correctly. MD320 inverter will configure the standard motor parameters according to the nameplate parameters. Vector control mode is highly dependent on the motor parameters and correct parameters must be acquired for achieving good control performance.

Motor auto tuning procedures:

Firstly set the command source (F0-02) as the operation panel command channel.

Then input the following parameters according to the actual parameters of motor:

F1-01: Rated power of motor

F1-02: Rated voltage of motor

F1-03: Rated current of motor

F1-04: Rated frequency of motor

F1-05: Rated speed of motor

## Chapter 4 Operation and Display

If the motor is disconnected from the load completely, select “2” (complete tuning) in F1-11, and press RUN in keypad, the inverter will calculate the parameters below automatically:

F1-06: Stator resistance

F1-07: Rotor inductance

F1-08: Leakage inductance

F1-09: Mutual inductance

F1-10: Excitation current with no load

Motor tuning is finished automatically.

If the motor cannot disconnect from its load, set F1-11 to 1 (static tuning), and then press the RUN.

The inverter will measure the stator resistance, rotor resistance and leakage inductance in sequence, but it will not calculate the mutual inductance and the excitation current with no load, and the user can use the nameplate parameters that are rated voltage U, rated current I, rated frequency f and power factor  $\eta$  to calculate these two parameters:

The calculation methods of the motor current with no load and the mutual inductance are described as follows.

$$\text{Excitation current with no load: } I_0 = I_n \cdot \sqrt{1 - \eta^2}$$

$$\text{Mutual inductance calculation: } L_m = \frac{\mu}{2\sqrt{3} \pi f I_0} - L_\sigma$$

Where  $I_0$  is the excitation current with no load,  $L_m$  is the mutual inductance and  $L_\sigma$  is the leakage inductance.





## Chapter 5 Function Parameters

MD300 inverter's function parameters are classified into 8 groups, namely, F1~F6, FF and FP. Each function group has several function codes. The function code uses 3-level menu. "F A-BC" word in this manual means No. "BC" function code in group "A". For example, "F6-08" means the No.8 function code in group F6.

For the purpose of convenient function code setting, when conducting operation via the operation panel, the function group number corresponds to the first level menu, the function code number corresponds to the second level menu, and function code parameters correspond to the third level menu.

Contents in the function table:

In column 1, "Function Code" means the code for the function parameter group and the parameter; "Name" in column 2 means the complete name of the function parameter; "Setting Range" in column 3 means the parameter setting range; "Min. Unit" in column 4 means the minimum unit of the function parameter setting; "Default" in column 5 means the original default and "Modified" in column 6 means the modification attributes of the parameters, i.e. whether to enable the modification and the modification requirements:

"○" means that the parameter can be modified while the inverter is running or stops.

"×" means that the parameter can not be modified while the inverter is running

"\*" means that the parameter value is actually measured value and cannot be modified;

"-" means that this parameter is default and can only be set by the manufacturer, whereas users' operation is forbidden.

(The inverter has already set the automatic check restriction to the modification attributes of the parameters so as to prevent the user from making wrong modification to the parameter.)

"Default" means the numeric value after the function code parameter is refreshed when restoring the default parameter, but the actual measured value or recorded value will not be refreshed.

The inverter provides password for function code operations to effectively protect the parameters. After the user password is set (. i.e. user password FP-00 is not set as 0), when the user presses **PRG** to enter

the function code editing status, the system will enter the user password verification status earlier, or it cannot enter. For the defaults, only when the user inputs the factory password, can he enter the system. (Note: It is not recommended for the user to modify the default, otherwise the inverter will work abnormally or be damaged.)

## Chapter 5 Function Parameters

The user can change the user password any time if the password protection is unlocked, and only the last password input is valid. +

Setting FP-00 to 0 can cancel the password and setting FP-00 as non-zero will enable the password protection when powering on.

Func. Code	Name	Setting Range	Min. unit	Default	Modified	Serial No.
<b>F0 Group Basic Function Group</b>						
F0-00	Control mode	0: Speed sensorless vector control (SVC)	1	0	×	0
F0-01	Command source selection	1: Reserved 2: V/F control 0: Operation panel (LED Off); 1: Terminal (LED On);	1	0	○	1
F0-02	Frequency source selection	0: Digital setting (not memorize)	1	0	×	2
		1: Digital setting (memorize) 2: Pulse setting (DI4) 3: AI1 4: AI2 5: Multi-speed				
F0-03	Auxiliary frequency source selection	0: Invalid 1: Valid (auxiliary frequency source is AI2 and only corresponds to 0, 1 and 2 of F0-02)	1	0	×	3
F0-04	Digital preset frequency	0.00Hz ~ Maximum frequency (valid if the frequency source selection mode is digital setup)	0.01 Hz	50.00Hz	○	4
F0-05	Acceleration time	0.0 ~ 3000.0s	0.1s	20.0s	○	5
F0-06	Deceleration time	0.0 ~ 3000.0s	0.1s	20.0s	○	6
F0-07	V/F curve selection	0: line V/F curve 1: Reserved 2: square V/F curve	1	0	×	7
F0-08	V/F control torque boost	0.0: (automatic) 0.1%~30.0%	0.1%	0.0%	○	8



Chapter 5 Function Parameters						
Func. Code	Name	Setting Range	Min. unit	Default	Modified	Serial No.
F0-09	DI1 terminal function selection	0: No function	1	1	×	9
F0-10	DI2 terminal function selection	1: Forward running (FWD)	1	4	×	10
F0-11	DI3 terminal function selection	2: Reverse running (REV)	1	12	×	11
F0-12	DI4 terminal function selection	3: 3-line control	1	13	×	12
		4: Forward jog (FJOG)				
		5: Reverse jog (RJOJ)				
		6: Terminal UP				
		7: Terminal DOWN				
		8: Coast to stop				
		9: Fault reset (RESET)				
		10: Reserved				
		11: External fault input				
		12: Multi-speed terminal 1				
		13: Multi-speed terminal 1				
		14: Reserved				
		15: Reserved				
		16: Switching between A11 and A12				
		17~18: Reserved				
		19: UP/DOWN setting clearance (terminal and keypad)				
		20: Running command switching terminal				
		21: Reserved				
		(When selecting PULSE, any function of DI4 is invalid and can only correspond to PULSE input.)				
F0-13	DO output selection	0: No output	1	1	○	13
		1: Inverter is running				
		2: Fault output				
		3: Frequency reaching				
F0-14	AO output selection	0: Running frequency	1	0	○	14
		1: Setting frequency				
		2: Output current				
		3: PULSE input (corresponding setup)				
		4: A11 (corresponding setup)				
		5: A12 (corresponding setup)				
F0-15	Start mode	0: Direct start	1	0	×	15
		1: Rotation velocity tracking restart				
F0-16	Stop mode	0: Deceleration stop	1	0	○	16
		1: coast to-stop				
<b>F1 Group Motor Parameter</b>						
F1-00	Motor type selection	0: Common asynchronous motor	1	0	×	17
		1: Inverter asynchronous motor				
		2: Permanent magnetic synchronous motor (Reserved)				
F1-01	Rated power	0.1~1000.0kW	0.1	Depending		

				inverter model	×	18
F1-02	Rated voltage	0~440V	1	380V	×	19

Chapter 5 Function Parameters						
Func. Code	Name	Setting Range	Min. unit	Default	Modified	Serial No.
F1-03	Rated current	0.00~655.35A	0.01	Depending on inverter model	×	20
F1-04	Rated frequency	0.00Hz ~ Maximum frequency	1	50.00Hz	×	21
F1-05	Rated speed	0 ~ 30000rpm	1	1460rpm	×	22
F1-06	Stator resistance	0.001 ~ 65.535 Ω	0.001 Ω	Depending on inverter model	○	23
F1-07	Rotor inductance	0.001 ~ 65.535 Ω	0.001 Ω	Depending on inverter model	○	24
F1-08	Leakage inductance	0.01 ~ 655.35mH	0.01 mH	Depending on inverter model	○	25
F1-09	Mutual inductance	0.1 ~ 6553.5mH	0.1 mH	Depending on inverter model	○	26
F1-10	Excitation current	0.01 ~ 650.00A	0.01A	Depending on inverter model	○	27
model						
F1-11	Tuning selection	0: No tuning 1: Static tuning 2: Complete tuning	1	0	×	28
<b>F2 Group Vector and VF Control Parameter</b>						
F2-00	Proportional gain 1 of speed loop of vector control	0 ~ 100	1	30	○	29
F2-01	Integration time 1 of speed loop of vector control	0.01 ~ 10.00s	0.01s	0.50s	○	30
F2-02	Switching frequency 1 of vector control parameter P1	0.00 ~ F2-05	0.01 Hz	5.00Hz	○	31
F2-03	Proportional gain 2 of speed loop of vector control	1~ 100	1	25	○	32
F2-04	Integration time 2 of speed loop	0.01 ~ 10.00s	0.01s	1.00s	○	33
F2-05	Switching frequency 2 of vector control parameter	F2-02 ~ 50.00Hz	0.01 Hz	10.00Hz	○	34
F2-06	Slip compensation coefficient of vector control	AVR selection				
F2-07	Filter time of speed loop/VF control	F2-08 Torque upper limit of vector control				



50% ~ 200%	1%	0.000~1.000s	35	0.001s	0.002s	○	36
		5.0~200.0%		0.1%	150.0%	○	37

Chapter 5 Function Parameters						
Func. Code	Name	Setting Range	Min. unit	Default	Modified	Serial No.
F2-09	Slip compensation coefficient of V/F control	0.0~200.0%	0.1%	0.0%	<input type="radio"/>	38
F2-10	Resonance suppressing gain of V/F control	0~100	1	0	<input type="radio"/>	39
<b>F3 Group Terminal Input and Output</b>						
F3-00	Terminal control mode (FWD/REV)	0: Two-line mode 1: Three-line mode	1	0	<input checked="" type="checkbox"/>	40
F3-01	Terminal UP/DOWN velocity	0.01~100.00Hz/s	0.01Hz/s	1.00 Hz/s	<input type="radio"/>	41
F3-02	AI minimum input	0.00~10.00V	0.01V	0.00V	<input checked="" type="checkbox"/>	42
F3-03	Corresponding setting of AI minimum input	100.0~100.0%	0.1%	0.0%	<input checked="" type="checkbox"/>	43
F3-04	AI intermediate 1 input	0.00~10.00V	0.01V	5.00V	<input checked="" type="checkbox"/>	44
F3-05	Corresponding setting of AI intermediate 1 input	-100.0~100.0%	0.1%	50.0%	<input checked="" type="checkbox"/>	45
F3-06	AI intermediate 2 input	0.00~10.00V	0.01V	8.00V	<input checked="" type="checkbox"/>	46
F3-07	Corresponding setting of AI intermediate 2 input	100.0~100.0%	0.1%	80.0%	<input checked="" type="checkbox"/>	47
F3-08	AI maximum input	0.00~10.00V	0.01V	10.00V	<input checked="" type="checkbox"/>	48
F3-09	Corresponding setting of AI maximum input	-100.0~100.0%	0.1%	100.0%	<input checked="" type="checkbox"/>	49
F3-10	PULSE input maximum frequency	0.00~50.00KHz	0.01Hz	50.00KHz	<input type="radio"/>	50
F3-11	Input filter time	0.01~10.00s	0.01s	0.01s	<input type="radio"/>	51
F3-12	AO zero offset coefficient	-100.0%~100.0%	0.1%	0.0%	<input type="radio"/>	52
F3-13	AO gain	-10.00~10.00	0.01	1.00	<input type="radio"/>	53
<b>F4 Group Start/Stop Control Parameters</b>						
F4-00	DC brake initial frequency at stop	0.00Hz ~50.00Hz	0.01 Hz	0.00Hz	<input type="radio"/>	54
F4-01	DC brake waiting time at stop					
F4-02	DC brake current at stop					
F4-03	DC brake time at					

0.0 ~ 36.0s	0.1s	0.0s 0.0 ~ 36.0s	○	55	0.1s	0.0s	○	57
0 ~ 100%	1%	0%	○	56				
F4-04	Braking utility rate	0 ~ 100%			1%	100%	○	58
<b>F5 Group Protection Function</b>								
F5-00	Motor overload protection selection	0: Disabled 0: Enabled			1	1	○	59

Chapter 5 Function Parameters						
Func. Code	Name	Setting Range	Min. unit	Default	Modified	Serial No.
F5-01	Motor overload protection coefficient	0.50~10.00	0.01	1.00	○	60
F5-02	Over voltage stall gain	0 (no over voltage stall)~100	1	0	○	61
F5-03	Over voltage stall action value	120~150%	1%	130%	○	62
F5-04	Over current stall gain	0 (no over current stall)~100	1	20	○	63
F5-05	Over current stall action value	100~200%	1%	150%	○	64
F5-06	Fault automatic reset times	0~3	1	0	○	65
F5-07	Fault automatic reset interval	0.1~100.0s	0.1s	1.0s	○	66
F5-08	Input phase failure protection selection	0: Disabled 1: Enabled	1	1	○	67
F5-09	Inverter offload protection selection	0: Disabled 1: Enabled	1	1	×	68
F5-10	Fault type	0: No fault 1: Inverter unit protection (ERR01) 2: Acc over current (ERR02) 3: Dec over current (ERR03) 4: Over current at constant speed (ERR04) 5: Acc over voltage (ERR05) 6: Dec over voltage (ERR06) 7: Over voltage at constant speed (ERR07) 8: Control power supply fault (ERR08) 9: Under voltage fault (ERR09) 10: Inverter overload (ERR10) 11: Motor overload (ERR11) 12: Input phase failure (ERR12) 13: Output phase failure (ERR13) 14: Heat sink overheat (ERR14) 15: External fault (ERR15) 16: Reserved 17: Reserved 18: Current detection failure (ERR18) 19: Motor tuning failure (ERR19) 20: Reserved 21: EEPROM memory fault (ERR21) 22: Hardware failure				23 : Motor earth short circuit (ERR23) 24 : Reserved

		-	0	*	69
F5-11	Frequency at fault	-	0.01H z	0.00Hz	* 70

Chapter 5 Function Parameters						
Func. Code	Name	Setting Range	Min. unit	Default	Modified	Serial No.
F5-12	Current at fault	-	0.01A	0.00A	*	71
F5-13	Bus voltage at fault	-	0.1V	0.0V	*	72
<b>F6 Group Auxiliary Function</b>						
F6-00	Maximum output frequency	50.00~300.00Hz	0.01Hz	50.00Hz	×	73
F6-01	Frequency upper limit	Frequency lower limit~ Maximum output frequency	0.01Hz	50.00Hz	○	74
F6-02	Frequency lower limit	0.00Hz ~ frequency upper limit	0.01Hz	0.00Hz	○	75
F6-03	Carrier frequency	0.5~16.0KHz	0.1KHz	Depending on the inverter model	○	76
F6-04	Jog frequency	0.00~50.00Hz	0.01Hz	2.00Hz	○	77
F6-05	Jog acceleration time	0.0 ~ 3000.0s	0.1	20.0s	○	78
F6-06	Jog deceleration time	0.0 ~ 3000.0s	0.1	20.0s	○	79
F6-07	Run reverse control	0: Run reverse enabled 1: Run reverse disabled	1	0	○	80
F6-08	FWD/REV dead zone time	0.0 ~ 3000.0s	0.1s	0.0s	○	81
F6-09	Start protection function	0: No protection 1: Protection	1	0	○	82
F6-10	Frequency reaching checkout amplitude value	0.0 ~ 100.0%(Maximum output frequency)	0.1%	0.0%	○	83
F6-11	MF.K function selection	0: No function 1: Switching between local operation and remote operation 2: Forward/Reverse switching 3: Jog	1	0	×	84
F6-12	Function of STOP/RESET key	RESET function is valid in all status. 0: STOP function is invalid under terminal control 1: Stop function is valid under terminal control	1	0	○	85
F6-13	Earth short circuit protection detection selection	0: Invalid 1: Valid	1	1	×	86
F6-14	Multi-speed 0	Negative maximum frequency ~ maximum frequency				maximum
F6-15	Multi-speed 1	Negative maximum frequency ~				m

		frequency	0.1Hz	0.0Hz	<input type="radio"/>	87
F6-16	Multi-speed 2	Negative maximum frequency ~ maximum frequency	0.1Hz	5.0Hz	<input type="radio"/>	88
F6-17	Multi-speed 3	Negative maximum frequency ~ maximum frequency	0.1Hz	10.0Hz	<input type="radio"/>	89
			0.1Hz	15.0Hz	<input type="radio"/>	90

Chapter 5 Function Parameters						
Func. Code	Name	Setting Range	Min. unit	Default	Modified	Serial No.
F6-18	Heat sink temperature	0~150℃	1℃		*	91
F6-19	Software version No.	00.00~99.99	0.01	Current software version No.	*	92
<b>FF Group Factory Parameters</b>						
FF-00	Factory password	0~65535	1	-	○	93
<b>FP Group User Password and Parameter Initialization</b>						
FP-00	User password	0~65535	1	0	○	103

FP-01 Parameter initialization  
 0: No operation  
 1: Default recovery  
 2: Fault clearance  
 1 0 × 104





## Chapter 6 Parameter Description

### F0 Group: Basic Function Group

F0-01	Control mode		Default	0
	Setting range	0	Speed sensorless vector control (SVC)	
		1	Reserved	
		2	V/F control	

#### 0: Speed sensorless vector control

It refers to the open-loop vector and is applicable to general control situation with high performance. One inverter can drive only one motor, such as machine tool, centrifugal machine, wire drawing machine, injection mould machine and other loads.

#### 2: V/F control

It is applicable to the situation in which the control precision requirements are low, such as inlet fan and pump serial loads. It can be applied to the situation in which one inverter drives multiple motors.

**Note:** It needs to distinguish the motor parameters to select the vector control mode. See Section 4.5 for details.

F0-01	Command source selection		Default	0
	Setting range	0	Operating panel (LED Off)	
		1	Terminal command (LED On)	

Select the control command channels of the inverter.

The control commands of the inverter include start, stop, forward rotation, reverse rotation, jog, etc.

#### 0: Operating panel command channel (LOCAL/REMOT is OFF).

Press the buttons such as RUN, STOP/RES on the operation panel to perform the command control. If the multifunctional key is set as FWD/REV switching function (set as No.2 in F6-11), this key can be used to alter the running direction.

#### 1: Terminal command channel (LOCAL/REMOT is ON).

Perform the command control by the multifunctional input terminals such as FWD, REV, JOGF, JOGR,

etc.

F0-02	Setting range	Chapter 6 – Parameter Description	
		Main frequency source X selection	Default 0
		0	Digital setting UP/DOWN (not memorize)
		1	Digital setting UP/DOWN (memorize)
		2	Pulse setting (DI4)
		3	A11
4	A12		
5	MS speed		

Select the input channels of the main reference frequency for the inverter. There are 6 main reference frequency channels, such as:

0: Digital setting (not memorize)

The initial value equals to that of F0-04 “Digital setup preset frequency”. It can modify the setup frequency value of the inverter by using the keys ▲ and ▼ (or the buttons of UP and DOWN of the multifunctional input terminal.)

Not memorize means that the setup frequency value can be recovered as that of F0-04 “Digital setup preset frequency” when the inverter is powered down.

1: Digital setting (memorize)

The initial value equals to that of F0-04 “Digital setup preset frequency”. It can modify the setup frequency value of the inverter by using the keys of ▲ and ▼ (or the buttons of UP and DOWN of the multifunctional input terminal.)

Memorize means that the setup frequency value can be recovered as that before power off.

2. Pulse setting (DI4)

The frequency reference is set through the terminal pulse.

Pulse reference signal specifications: Pulse voltage range: 9~30V; pulse frequency range: 0~50KHz.

Note: The pulse reference can only be input via the multifunctional input terminal.

3: A11

4: A12

They mean that the frequency is determined by the analog input terminal. The standard unit of MD300

series inverters provides two analog input terminals, in which AI1 is 0~10 V voltage input, while AI2 can be either the 0~10 V voltage input or 0~20mA current input, which is selected by the J3 jumper on the control panel.

5: MS speed

Chapter 6 – Parameter Description

Select the MS speed running mode. It needs to set the DI input terminal and the parameters of Group F6-14~F6-17 to identify the relative relations between the reference signal and reference frequency.

F0-03	Auxiliary frequency source selection	Default	0
	0	Invalid	
Setting range	1	Valid. The auxiliary frequency source is A12 and only corresponds to No. 0, 1 and 2 of F0-02.	

The auxiliary frequency source has only one A12 channel. And it is enabled only when No. 0, 1 and 2 are selected in F0-02.

F0-04	Command source selection	Default	50.00Hz
Setting range	0.00~ maximum frequency (enabled when the frequency source selection mode is digital setting)		

When the main frequency source is selected as “Digital setting”, this function code value is the digital setting initial value of the inverter’s frequency.

F0-05	Acc time	Default	20.0
F0-06	Dec time	Default	20.0
Setting range	0.0~3000.0s		

Acc time refers to the time “t1” required for the inverter to accelerate from 0Hz to the maximum output frequency (F6-00).

Dec time refers to the time “t2” required for the inverter to decelerate from maximum output frequency to 0Hz (F6-00).

See the following figure.

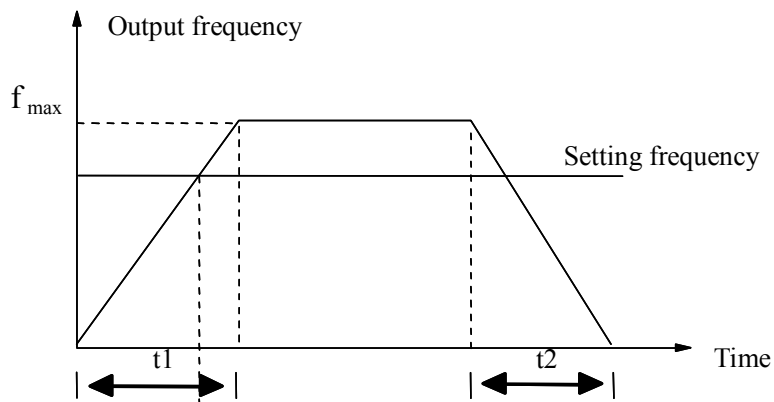

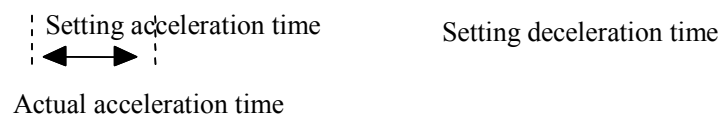

Fig. 6-1 Acceleration/Deceleration Time Schematic Diagram

Chapter 6 – Parameter Description			
Attention shall be paid to the difference between the actual Acc/Dec time and the setting Acc/Dec time.			
F0-07	V/F curve setting	Default	0
	0	Line V/F curve	
	Setting range 1	Reserved	
	2	Square V/F curve	

For the loads such as fan and pump, the square V/F curve may be suitable.

0: Line V/F curve, applicable to loads with ordinary constant torque.

2: Square V/F curve, applicable to centrifugal loads, such as fan and pump.

F0-08	V/F control torque boost	Default	0.0%
	Setting range	0.0: (Automatic) 0.1%~30%	

Some boost compensations are given to the output voltage when the inverter is at low frequency in order to compensate the V/F control low frequency torque feature.

High torque boost setting value is easy to result in overheating of the motor and over current of the inverter. Normally, the torque boost shall not be over 8%.

By effectively adjusting this parameter, it can avoid the occurrence of over current when the inverter is being started. In the applications requiring high loads, it is recommended to increase this parameter value. Otherwise it is to be decreased.

When the torque boost is set as “0”, the inverter implements torque boost automatically.

F0-09	DI1 terminal function selection	Default	1 (Forward running)
F0-10	DI2 terminal function selection	Default	4 (Forward jog)
F0-11	DI3 terminal function selection	Default	12 (MS speed 1)
F0-12	DI4 terminal function selection	Default	13 (MS speed 2)

This parameter is used to set the functions corresponding to the digital multifunctional input terminals. When the PULSE input is selected, DI4 is disabled for any function except for the PULSE input.

Setting Value	Function	Description
0	No function	The inverter does not run even there is signal. The unused terminals can be set as “No function” to



---

		prevent error operation.
1	Forward running (FWD)	The forward running and reverse running is controlled via the external terminal.
2	Reverse running (REV)	
3	Three-line	This terminal is used to confirm that the running

Chapter 6 Parameter Description		
	running control	mode of inverter is three-line control mode. See F3-00 for details on the introduction of the three-line control mode.
4	Forward jog (FJOG)	FJOG refers to jog forward running, and RJOG refers to jog reverse running. See F6-04, F6-05 and F6-06 for details on the jog running frequency and jog acceleration/deceleration time.
5	Reverse jog (RJOG)	
6	Terminal UP	It can be used to modify the increment command
7	Terminal DOWN	and decrement command when the frequency is set by the external terminals; it can be used to adjust the setting frequency when the frequency source is set as “digital setting”.
8	Coast to stop	If the inverter output is locked, the motor stop is beyond the control of inverter. It is often employed for the loads with high inertia and when there is no requirement for the stop time. This mode is the same as that described in F0.16.
9	Fault reset (Reset)	The external fault reset function. It is identical with the RESET key and can be used to implement remote fault reset.
11	External fault input	When the external fault signal is sent to the inverter, the inverter reports fault and stops.
12	MS speed terminal 1	The combination of digital status of the two terminals can realize 4 MS speed settings. See attached fig. 1 for details on the combination.
13	MS speed terminal 2	

Setting Value	Function	Description
16	Switching between A11 and A12	Enabled only when A11 or A12 is selected in F0-02 “Frequency source selection”.
19	UP/DOWN setting clearance (terminal and keypad)	When the frequency reference is digital frequency reference, this terminal may be used to clear the frequency value modified by UP/DOWN to restore the referenced frequency to the value set in F0.04.
20	Switching terminal for the running commands	When the command source (F0-01) is set as “1”, this terminal can be used to switch the terminal control and the key control.

K <sub>2</sub>	K <sub>1</sub>	Frequency Setting	Corresponding Parameter
OFF	OFF	MS speed 0	MS speed 0
OFF	ON	MS speed 1	MS speed 1
ON	OFF	MS speed 2	MS speed 2
ON	ON	MS speed 3	MS speed 3

Chapter 6 Parameter Description			
Attached Fig. 1			
F0-13	DO output selection (Open collector output terminal)	Default	1 (the invert is running)
	Setting range	0~3	

Setting Value	Function	Description
0	No output	The output terminal has no function
1	Inverter is running	It indicates that the inverter is running with output frequency. Meanwhile there is ON signal output.
2	Fault output	When the inverter is faulty, ON signal will be output.
3	Frequency arrival	See F6-10 for details.

F0-14	Output selection (analog output terminal)	Default	0.0%
	Setting range	0~5	

The standard output of analog output is 0~20mA (or 0~10V).

Its corresponding value range is shown in the table below.

Setting Value	Function	Description	
0	Running frequency	0~ maximum output frequency	
1	Setting frequency	0~ maximum output frequency	
2	Output current	0~2×rated current of inverter	
3	PULSE input	0.1~50.0KHz	
4	A11	0~10V	
5	A12	0~10V/0~20mA	
F0-15	Output selection (analog output terminal)	Default	0.0%
	0	Direct start	

Setting range 1      Rotation velocity tracking restart

0: Direct start

Start with start frequency

## Chapter 6 Parameter Description

## 1: Rotation velocity tracking restart

The inverter first judges the rotation velocity and direction of the motor and then starts with the frequency corresponding to the tracked rotation velocity of motor. And the motor that is rotating is started in a smooth mode (The default tracking frequency is the frequency before stopping).

It is applicable to the momentary power-off restart with high inertia.

To ensure the performance of the rotation velocity tracking restart, it is necessary to set the motor parameters accurately (F1 group).

F0-16	Stop mode		Default	0
	Setting range	0	Dec stop	
		1	Coast to stop	

## 0: Dec stop

Once the stop command is enabled, the inverter will reduce the output frequency according to the deceleration mode and the defined acceleration/deceleration time. When the frequency is decreased till "0", the inverter will power off.

## 1: Coast to stop

After the stop command is enabled, the inverter will terminate the output immediately and the loads implement coast to stop with the mechanical inertia.

**F1 Group: Motor Parameters**

F1-00	Motor type selection		Default	0
	Setting range	0	Common asynchronous motor	
		1	Variable frequency asynchronous motor	
		2	Permanent magnetic synchronous motor	

F1-01	Rated power		Default	Depending on inverter model
	Setting range	0.4~1000.0kW		
F1-02	Rated voltage		Default	380V
	Setting range	0~440V		
F1-03	Rated current		Default	Depending on inverter model
	Setting range	0.00~655.35A		

F1-04	Rated frequency	Default	50.00Hz
	Setting range	0.00Hz~Maximum frequency	
F1-05	Rated rotation Velocity	Default	1460rpm
	Setting range	0~30000rpm	

**Note:**

## Chapter 6 Parameter Description

Please set according to the nameplate parameters of the motor. The excellent control performance of vector control depends on the accurate motor parameters. The accurate parameter identification is based on the correct setting of the motor rated parameters.

Please perform the motor configuration according to the standard adaptable motor of the inverter in order to guarantee the control performance. If the difference between the motor power and the standard adaptable motor is too large, the control performance of the inverter will greatly reduce.

F1-06	Stator resistance	Default	Depending on inverter model
	Setting range	0.001~65.535 Ω	
F1-07	Rotor resistance	Default	Depending on inverter model
	Setting range	0.001~65.535 Ω	

F1-08	Leakage inductance	Default	Depending on inverter model
	Setting range	0.01~655.35mH	
F1-09	Mutual inductance	Default	Depending on inverter model
	Setting range	0.1~6553.5mH	
F1-10	Excitation current	Default	Depending on inverter model
	Setting range	0.01~650.00A	

If the automatic tuning of the motor is completed normally, the setup values in F1-06 to F1-10 will update automatically.

If modifying the motor rated power, the parameter values of the inverter in F1-06 to F1-10 will automatically recover to the default standard motor parameters. (Quadruple Y series induction motor)

If the motor cannot be tuned on the site, the known parameters of the same kind of motors can be a reference for manual input.

F1-11	Tuning selection	Default	0
	Setting range	0	No tuning
		1	Static tuning
		2	Complete tuning

**Note:** The correct motor rated parameters (F1-01~F1-05) must be set before tuning.

0: No tuning, it means tuning is forbidden.



1: Static tuning, it is applicable to the situation in which the rotation tuning cannot be performed because it is difficult to separate the motor from the load.

Operation description: Set the function code as 1 and press the RUN button to identify, then the inverter will conduct the static tuning.

## Chapter 6 Parameter Description

## 2: Complete tuning

To ensure the dynamic control performance of the inverter, please select the rotation tuning. When performing the rotation tuning, the motor must be separated from the load (no-load).

After selecting the rotation tuning, the inverter will first perform the static tuning. When the static tuning is completed, the motor will be accelerated to 80% of the motor rated power according to the acceleration time set in F0-05. It will maintain this status for a period of time. Then it will be decelerated to zero according to the deceleration time set in F0-06. The rotation tuning is then over.

Operation description: Set the function code as 2 and press the RUN button to identify, then the inverter will conduct the rotation tuning.

Tuning operation description:

Press the ENTER key after the F1-11 is set as 1 or 2 to display “TUNE” that is flashing. And press the RUN button to perform the parameter tuning, the “TUNE” stops flashing and the “TUNE/TC” light is flashing. After the tuning is completed, it will display the stop status interface. When the “TUNE” is flashing, press the PRG button to exit from the tuning. Also the STOP button can be pressed in the tuning process to suspend the tuning.

After the tuning is completed, the values in F1-11 will automatically recover as 0.

## F2 Group: Vector Control and V/F Control Parameters

The function codes in Groups F2-00~F2-08 validate only for the vector control. That is to say, when F0-00=0, they are valid.

The function codes in F2-09~F2-10 are valid for the V/F control, i.e. when F0-00=2, they are valid.

F2-00	Proportional gain 1 of speed loop of vector control	Default	30
	Setting range	1~100	
F2-01	Integration time 1 of speed loop of vector control	Default	0.50s
	Setting range	0.01~10.00s	
F2-02	Switching frequency 1 of vector control	Default	5.00Hz
	Setting range	0.00~F2-05	
F2-03	Proportional gain 2 of speed loop of vector control	Default	25
	Setting range	0~100	
F2-04	Integration time 2 of speed loop of vector control	Default	1.00s
	Setting range	0.01~10.00s	

F2-05	Switching frequency 2 of vector control	Default	10.00Hz
	Setting range	F2-02~ Maximum output frequency	

The parameters of F2-00 and F2-01 refer to PI adjustment parameters when the running frequency is lower than the switching frequency 1 (F2-02), while the parameters of F2-03 and F2-04 refer to PI adjustment parameters when the running frequency is higher than the switching frequency 2 (F2-05).

## Chapter 6 Parameter Description

The PI adjustment parameter between the switching frequency 1 and switching frequency 2 refers to linear switching between two sets of PI parameters.

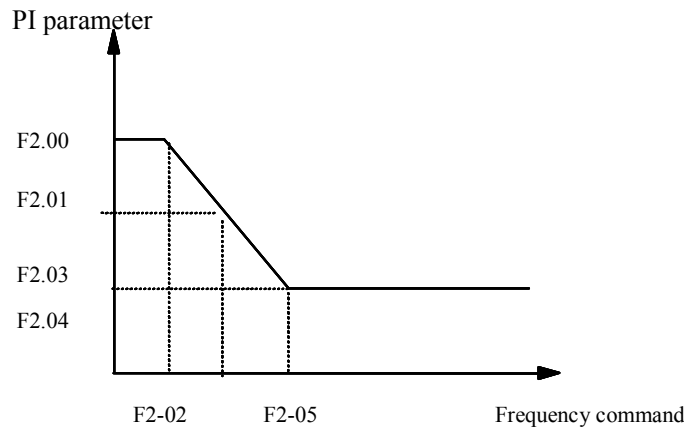

Fig. 6-2 PI Parameters Schematic Diagram

It can regulate the speed dynamic response characteristic of the vector control by setting the proportional coefficient and integration time of the speed regulator. It can accelerate the dynamic response of the speed loop by increasing the proportional gain or decreasing the integration time. Overlarge proportional gain or too small integration time will cause the system to vibrate.

The regulating method is recommended as follows:

If the factory parameters cannot fulfill the requirements, conduct minor adjustment on the basis of the factory parameters:

Enlarge the proportional gain first to prevent the system from vibrating, then diminish the integration time to ensure that the system has fast response characteristic and the overshoot is small.

**Note:** Once the PI parameters are set inappropriately, it will cause large overshoot speed even voltage fault when the overshoot returns to the normal level.

F2-06	Slip compensation coefficient of vector control	Default	100%
	Setting range	50%~ 200%	

This parameter is used to regulate the steady speed precision when the motor is loaded. This parameter value needs to be increased when the motor rotation velocity is low due to heavy load, or it will be decreased.

F2-07	Filter time of speed loop of vector control NF control AVR selection	Default	0.002s
	Setting range	0.000~0.100s	

## Chapter 6 Parameter Description

Under the vector control mode, the speed loop regulator outputs the torque current command. This parameter is used to filter the torque command and generally needs not to be adjusted. The filter time may be increased considerably when the speed fluctuates dramatically. If the motor vibrates, it is better to decrease this parameter appropriately.

Under the VF control mode, this parameter acts as the AVR selection function code of VF.

Under 0.000: VF control, AVR is always invalid.

Under 0.001: VF control, AVR is always valid.

Under 0.002: VF control, AVR is only valid at deceleration time.

If the function code value is higher than 0.002, it will be regarded as 0.002.

Under the VF control, when there is need to stop quickly but no braking resistor, selecting “Valid only at deceleration time” can greatly reduce the chances of generating over voltage fault alarm. But when there is braking resistor but no need for acceleration or deceleration, please select “AVR is always valid”.

F2-08	Torque upper limit of vector control	Default	150.0%
	Setting range	5.0~200.0%	

The setting value “100” corresponds to the rated output torque of the motor that matches the inverter.

F2-09	Slip compensation coefficient of V/F control	Default	0.0%
	Setting range	0.0~ 200.0%	

It is valid for the V/F control. It can compensate the slip resulted from the load by setting this parameter, thus diminishing the change quantity of the motor rotation velocity following the load change. In general, 100% corresponds to the rated slip when the motor is under the rated load. The following principles can be as a reference for the slip coefficient adjustment: If the load equals the rated load and the slip compensation coefficient is set as 100%, the rotation velocity of the motor attached to the inverter is close to the reference speed.

F2-10	Resonant suppressing gain of V/F control	Default	0
	Setting range	0~ 100	

If there is no mechanical resonance, this parameter should be 0. This gain shall be appropriately increased when the motor cannot run normally due to obvious resonance. The higher the gain is, the more effective the gain is suppressed. To prevent impact on the VF running, this gain shall be minimized on the condition that the resonance can be effectively suppressed.

Chapter 6 Parameter Description

**F3 Group: Terminal Input and Output**

F3-00	Terminal command mode	Default	0
		1	Two-line mode
		2	Three-line mode

This parameter defines two different running modes of the inverter controlled by the external terminal.

0: two-line Running Mode: The rotation direction of the motor depends on the FWD and REV terminals

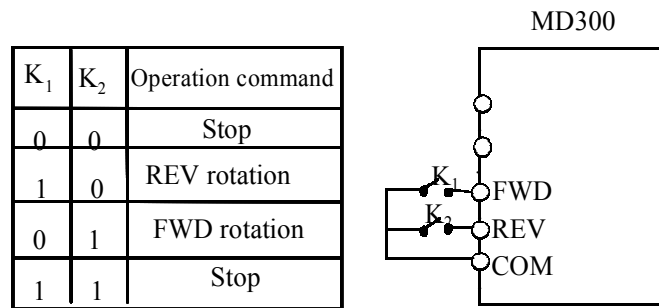

Fig. 6-3 Two-line Running Mode 1

1: Three-line Running Mode 1: The DIn of this mode is enable terminal. The direction is controlled by the FWD and REV. But the pulse is valid, so it must disconnect the DIn terminal signal to stop.

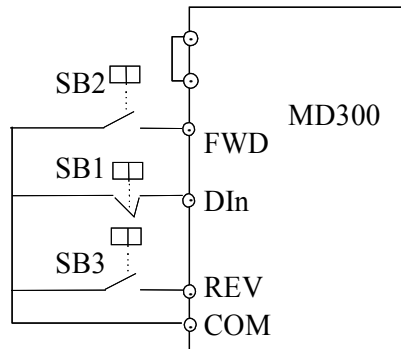

Fig. 6-4 Three-line Running Mode

Where:

SB1: Stop button

SB2: Forward Rotation Button



SB3: Reverse Rotation Button

DIn refers to the multifunctional input terminals between DI1 to DI4. At this time, the corresponding terminal function shall be defined as the 3<sup>rd</sup> function, “Three-line Running Control”.

## Chapter 6 Parameter Description

**Note:**

As for the two-line running mode, if the inverter stops because of the stop command generated by other sources, the inverter cannot run after the stop command disappears, even though the control terminal FWD/REV is still valid. To rerun it, you shall retrigger the FWD/REV. For example, the valid STOP button stop under the terminal running command channel (Refer to F6-12). However, the stop due to the fault alarm is different. It is the function code in F6-09 that controls whether it can run or not.

F3-01	Terminal UP/DOWN rate	Default	1.00Hz/s
	Setting range	0.01~100.00Hz/s	
The terminal UP/DOWN can be used to regulate the change rate when setting the frequency.			
F3-02	AI minimum input	Default	0.00V
	Setting range	0.00~10.00V	
F3-03	Setting corresponds to AI minimum input	Default	0.0%
	Setting range	-100.0%~100.0%	
F3-04	AI intermediate 1 input	Default	5.00V
	Setting range	0.00~10.00V	
F3-05	Setting corresponds to AI intermediate 1 input	Default	50.0%
	Setting range	-100.0%~100.0%	
F3-06	AI intermediate 2 input	Default	8.00V
	Setting range	0.00~10.00V	
F3-07	Setting corresponds to AI intermediate 2 input	Default	80.0%V
	Setting range	-100.0%~100.0%	
F3-08	AI maximum input	Default	10.00V
	Setting range	0.00~10.00V	
F3-09	Setting corresponds to AI maximum input	Default	100.0%
	Setting range	-100.0%~100.0%	

The above function codes define the relations between the analog input voltage setup value and the

analog input representative setup value. When the analog input voltage is over the setup maximum input or minimum input, it will be calculated according to the maximum input or minimum input. When the analog input equals to the current input, 1mA current is equivalent to 0.5V. The nominal value corresponding to the analog setup 100% varies with the application situation. For details, please refer to the description of each application part.

Chapter 6 Parameter Description

Following are diagrams for several setup examples.

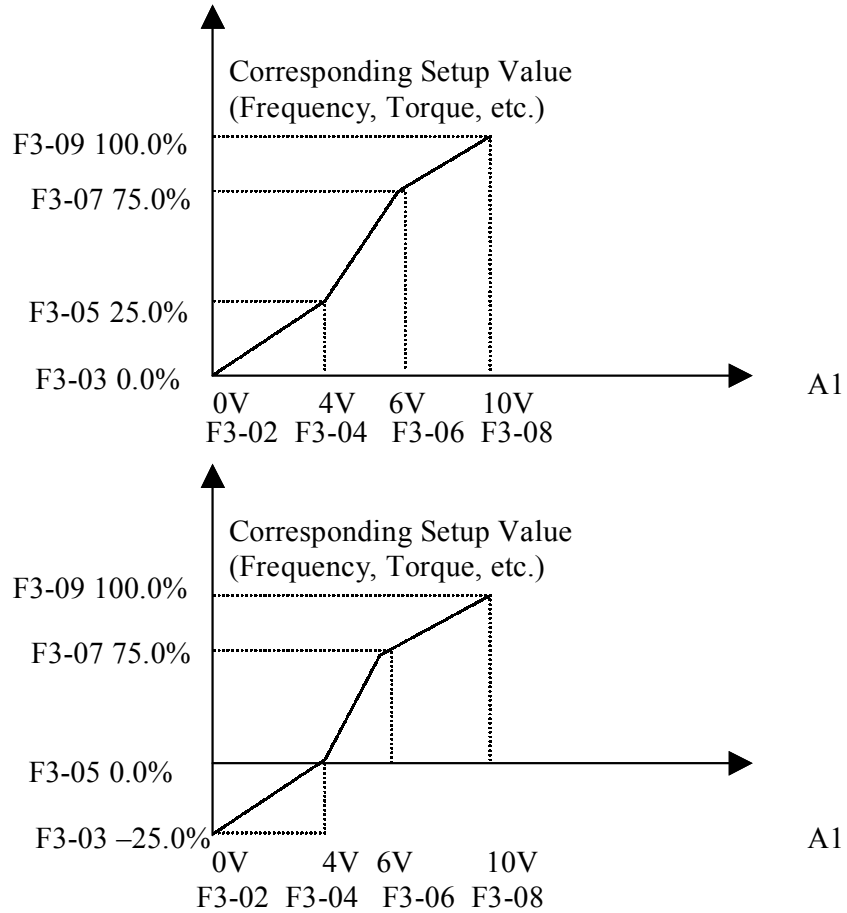

Fig. 6-5 The Corresponding Relations between the Analog Reference and the Setup Value

The method of setting the AI2 function is similar to that of AI1.



Chapter 6 – Parameter Description			
The MD300 inverter	standard unit provides two analog input interfaces.		
F3-10	PULSE input maximum frequency	Default	50.00KHz
	Setting range	0.00~50.00KHz	
F3-11	Input filter time	Default	0.01s
	Setting range	0.00~10.00s	

This group of function code defines the corresponding relations when the pulse is used as the frequency setup mode.

The pulse frequency input can only be input through the DI4 channel.

F3-12	AO zero offset coefficient	Default	0.00%
	Setting range	-100.0%~100.0%	
F3-13	AO gain	Default	1.00
	Setting range	-10.00~10.00	

If using letter “b” to indicate the zero offset coefficient, “k” to indicate the gain, “Y” to indicate the actual output and “X” to indicate the standard output, then the actual output equals as follows:

$$Y=kX+b$$

The AO zero offset coefficient 100% corresponds to 10V(20mA).

The standard output means that the output 0~10V(20mA) corresponds to the analog output 0~Maximum.

It is generally applied to modify the zero drift and the deviation of the output swing. It can also be defined as any needed output curve itself.

For example, if the analog output content is the running frequency, it is expected to output 8V (16mA) when the frequency equals to zero and to output 3V (6mA) when the frequency reaches maximum. Then the gain shall be set as “-0.50” and the zero offset coefficient shall be set as “80%”.



Chapter 6 Parameter Description			
<b>F4 Group: Start and Stop Control Parameters</b>			
F4-00	DC brake initial frequency at stop	Default	0.00Hz
	Setting range	0.00Hz~ Maximum frequency	
F4-01	DC brake waiting time at stop	Default	0.0s
	Setting range	0.0~36.0s	
F4-02	DC brake current at stop	Default	0%
	Setting range	0~100%	

F4-03 DC brake time at stop Default 0.0s  
Setting range 0.0~36.0s

DC Brake Initial Frequency at Stop: In the process of deceleration to stop, if this frequency is achieved, it starts the process of DC brake at stop.

DC Brake Waiting Time at Stop: Before starting the process of DC brake at stop, the inverter stops outputting and starts the DC brake at stop after this time.

It is used to prevent the over current fault that is probably generated by the DC brake at high velocity.

DC Brake Current at Stop: It refers to the added DC brake quantity. The larger it is, the better the DC brake effect is.

DC Brake Time at Stop: It refers to the added time of the DC brake quantity. If it equals 0, it indicates the DC brake process does not exist. And the inverter stops according to the setup acceleration stop process.

F4-04	Brake utility ratio	Default	100%
	Setting range	0~100%	

This parameter is valid for the inverter with built-in brake unit. It can regulate the brake effect of the brake unit.





**F5 Group: Fault and Protection**

		Chapter 6	Parameter Description
F5-00	Motor overload protection selection	Default	1

	Setting range	0: Disabled 1: Enabled	0: The inverter has no overload protection for the motor and the relay shall be heated. 1: the inverter has motor overloading protection and the protection value is shown in F5-01.
F5-01	Motor overload protection coefficient	Default	1.00

Setting range 0.20~10.00 The motor over sensitive protection is 220% \* F5-01 × motor rated current and 150 \* F5-01 × motor rated current 60- minute reverse time limit curve

F5-02	Over voltage stall gain	Default	0
	Setting range	0 ( no over voltage stall) ~100	Adjust the over voltage stall capacity of the inverter to avoid over voltage fault. The bigger is the value, the more powerful the suppressing capacity is. For the load with small inertia, the small value is recommended, or it will slow down the system dynamic response. For the load with large inertia, the big value is recommended, otherwise there will be over voltage fault due to poor suppressing effect.

F5-03	Over voltage stall action value	Default	130%
	Setting range	120~150%	Select the voltage protection value of the stall operation. The inverter starts executing the voltage stall protection function when this value is surpassed.

F5-04	Over current stall gain	Default	20
	Setting range	0(no over current stall) ~100	Adjust the over current stall capacity of the inverter to avoid over current fault. The bigger is the value, the more powerful the suppressing capacity is. For the load with small inertia, the small value is recommended, or it will slow down the system dynamic response. For the load with large inertia, the big value is recommended, otherwise there will be over current fault due

to poor suppressing effect.

<b>F5-05</b>	Over current stall action value		Default	150%
	Setting range	100~200%	Select the protection value of the over current stall function. The inverter starts executing the over current stall protection function when this value is surpassed.	

0989.984.666

## Chapter 6 Parameter Description

<b>F5-06</b>	Fault automatic reset times	Default	0
	Setting range	0~3	When the fault automatic reset function is selected for the inverter, the times that can be automatically reset is set. If this value is surpassed, the inverter is faulty and stops, waiting for maintenance.

<b>F5-07</b>	Fault automatic reset interval	Default	1.0s
	Setting range	0.1~100.0s	The time interval between the beginning of the fault and the implementation of automatic reset.

<b>F5-08</b>	Input phase failure protection selection	Default	1
	Setting range	0: Disabled 1: Enabled	Select whether to protect when the input phase failure occurs. Only the MD series inverters with more than 7.5G power have the function of input phase failure protection, whereas the inverters with power of less than 7.5G do not have this function no matter it is selected as "0" or "1".

<b>F5-09</b>	Inverter offload protection selection	Default	1
	Setting range	0: Disabled 1: Enabled	Select whether to protect when the offload occurs. When selecting the offload protection function and there is no load at the output end of the inverter, the output frequency of the inverter will automatically reduce to 2Hz.

<b>F5-10</b>	Fault type	0~24	Default
--------------	------------	------	---------

<b>F5-11</b>	Frequency at fault	Indicating the frequency when the latest fault occurs	
<b>F5-12</b>	Current at fault	Indicating the current when the latest fault occurs	
<b>F5-13</b>	Bus voltage at fault	Indicating the bus voltage when the latest fault occurs	

**F6 Group: Auxiliary Function**

<b>F6-00</b>	Maximum output frequency	Default	50.00Hz
	Setting range	50.00~300.00Hz	

It is used to set the maximum output frequency of the inverter.

---

<b>F6-01</b>	Frequency upper limit	Default	50.00Hz
	Setting range	Frequency lower limit F0-11 ~ Maximum frequency F6-00	

It refers to the output frequency upper limit of the inverter.

<b>F6-02</b>	Frequency lower limit	Default	0.00Hz
	Setting range	0.00Hz~ Frequency upper limit F6-01	

## Chapter 6 Parameter Description

When the inverter starts running, if the reference frequency is lower than the frequency lower limit, then the inverter has no output. During the running process, if the reference frequency is lower than the frequency lower limit, then the inverter will always be running with frequency lower limit till it stops or the reference frequency is higher than the frequency lower limit.

<b>F6-03</b>	Carrier frequency	Default	Depending on the inverter model
	Setting range	0.5~ 16.0kHz	

This function is used to adjust the carrier frequency of the inverter. Adjusting the carrier frequency may diminish the motor noise, avoid the resonant point of the mechanical system, reduce the grounding leakage current of the line, and decrease the interferences generated from the inverter.

When the carrier frequency is low, the output current harmonics will be increased, the motor loss will be augmented and the motor temperature rise will be increased too.

When the carrier frequency is high, the motor loss will be decreased and the motor temperature rise will be diminished. But the loss and temperature rise of the inverter will be added, so will the interference.



## Chapter 6 Parameter Description

Adjusting the carrier frequency may have influences on the following performances:

Carrier frequency	Low	High
Motor noise	High	Low
Output current wave form	Poor	Good
Motor temperature rise	High	Low
Inverter temperature rise	Low	High
Leakage current	Small	Large
Radiation interference	Small	Large

<b>F6-04</b>	Jog running frequency	Default	2.00 Hz
	Setting range	0.00Hz~ maximum frequency	

It is used to define the reference frequency of the inverter when jogging. Follow the start mode 0(F0-15, direct start) and the stop mode 0 (F0-16, deceleration stop) to start and stop the jogging process.

<b>F6-05</b>	Jog acceleration time	Default	20.0s
	Setting range	0.0~3000.0s	
<b>F6-06</b>	Jog deceleration time	Default	20.0s
	Setting range	0.0~3000.0s	

The jog acceleration time refers to the time required for the inverter to accelerate from 0Hz to the maximum frequency (F6-00).

The jog deceleration time refers to the time required for the inverter to decelerate from the maximum frequency (F6-00) to 0Hz.

<b>F6-07</b>	Run reverse control	Default	0
	Setting range	0	Run reverse enabled
		1	Run reverse disabled

If this parameter is selected as “0”, the reverse may be controlled by the keypad or terminal.

If this parameter is selected as “1”, the reverse control function is disabled no matter whether it is keypad control or terminal control.

<b>F6-08</b>	FWD/REV dead zone time	Default	0.0s
	Setting range	0.0~3000.0s	



It refers to the transition time at the zero output frequency when setting the FWD/ REV rotation transition of the inverter, as shown in Fig. 6-6.

Chapter 6 Parameter Description

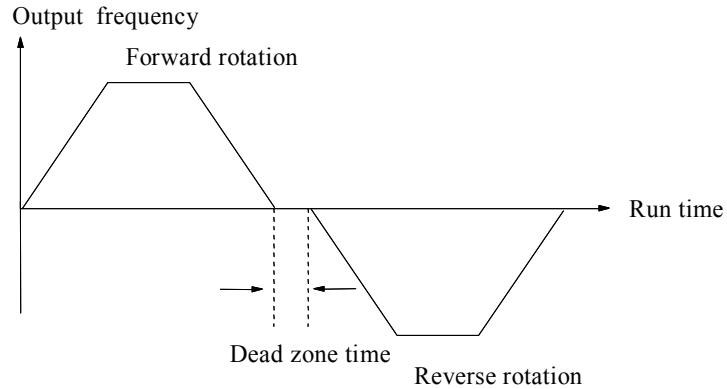

Fig 6-6 FWD/REV Dead Zone Time

<b>F6-09</b>	Start protection selection		Default	0
	Setting range	0	No protection	
		1	Protection	

This function code is used to enhance the security protection coefficient. If it is set as “1”, it has two functions: First, if the running command exists when the inverter is powered on, it must delete the running command to exit the running protection status. Second, if the running command still exists when the inverter implements fault reset, it must delete the running command to exit the running protection status.

This function can prevent the danger resulted from the unexpected running of the inverter.

<b>F6-10</b>	Frequency reaching checkout amplitude value		Default	0.0%
	Setting range	0.0~100.0%		

When the output frequency of the inverter reaches the setting frequency value, this function can adjust the detection amplitude value, as shown in the figure below.



Chapter 6 Parameter Description

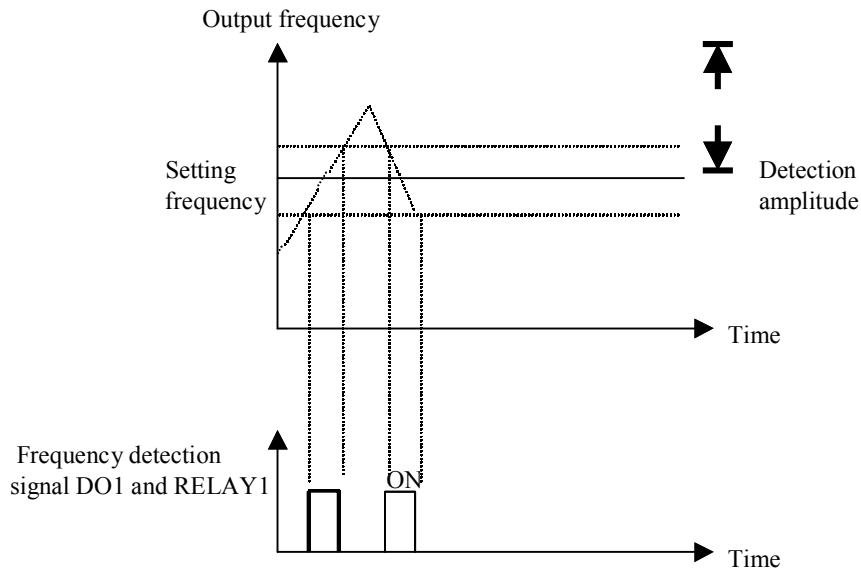

Fig. 6-7 Frequency Reaching Checkout Amplitude Value

<b>F6-11</b>	MF.K function selection		Default	2
	Setting range	0	MF.K key is invalid	
		1	Switching between the operation panel channel and the remote command channel (terminal command channel)	
		2	Switching between forward rotation and reverse rotation	
		3	Switching between forward jog and reverse jog	

MF.K refers to multifunctional key and its function can be defined through the parameter configuration. Switching operations can be implemented in the stop and start process by using this key.

0: Indicating that it has no function.

1: Switching between the keypad command and remote operation. It indicates the command source switching, that is, switching from the current command source to the keypad control (local operation). If the current command source serves as the keypad control, this command is disabled.

2: Switching between forward rotation and reverse rotation.

By using the MF.K, it can switch the frequency command direction. It is enabled only in the command channel of the operation panel.

3: Forward jog

By using the MF.K, it can implement forward jog (FJOG).

<b>F6-12</b>	Stop/RESET function		Default	0
	Setting range	0	The STOP function is invalid under the terminal control.	
		1	The STOP function is valid under the terminal control.	



		Chapter 6 Parameter Description	

The RESET function is valid under any status.

<b>F6-13</b>	Earth short circuit protection detection after power-on	Default	0
	Setting range	0: invalid 1: valid	

The inverter can be selected to detect whether or not the earth short circuit fault exists to the electric engine after power-on. If the function is valid, the inverter has a short-time output when powering on.

<b>F6-14</b>	MS speed 0	Default	0.0Hz
	Setting range	Negative maximum frequency~ maximum frequency	
<b>F6-15</b>	MS speed 1	Default	0.0Hz
	Setting range	Negative maximum frequency~ maximum frequency	
<b>F6-16</b>	MS speed 2	Default	0.0Hz
	Setting range	Negative maximum frequency~ maximum frequency	
<b>F6-17</b>	MS speed 3	Default	0.0Hz
	Setting range	Negative maximum frequency~ maximum frequency	

When the frequency source is selected as MS speed (F0-02=5), the values of F6-14~F6-17 must be set.

<b>F6-18</b>	Heat sink temperature	Default	
	Setting range	0.0~150.0°C	Displaying the temperature of the heat sink

<b>F6-19</b>	Software version No.	Default	Current software version No.
--------------	----------------------	---------	------------------------------

### FF Group: Manufacturer Parameter(Reserved)

### FP Group: User Password

<b>FP-00</b>	User password	Default	0
	Setting range	0~65535	

When the password is set as any non-zero number, the password protection function comes into effect.

0000: The password protection function is invalid.

Upon the setting and validation of user password, enter the parameter setting status again and you may only view the parameter and cannot modify the parameter if the user password is incorrect.

Remember the user password being set. If you do forget or wrongly set the password, please contact the manufacturer.

<b>FP-01</b>	Parameter initialization	Default	0
	Setting range	0	No operation
		1	Recover the default
		2	Clear the fault records

1: The inverter will restore all parameters to the default ones.

Chapter 6 Parameter Description

2: The inverter will remove the latest fault records.





## Chapter 7 Fault Diagnosis and Countermeasures

### 7.1 Fault Alarm and Countermeasures

The MD300 inverter has 21 pieces of alarm information and protection functions in total. Once the fault occurs, the protection function starts, the inverter stops inputting, the fault relay contact point is activated, and the fault code will be displayed on the display panel of the inverter. Before seeking services, the subscriber may conduct the self-check according to the prompt given in this section, analyze the fault causes, and find out the solutions. If the fault belongs to the causes described in the broken line box, please seek the service by contacting the inverter agent or directly contacting our corporation.

Among the 21 pieces of alarm information, Err22 serves as the hardware over current and over current signal. In most cases, the Err alarm is caused by the hardware over voltage fault.

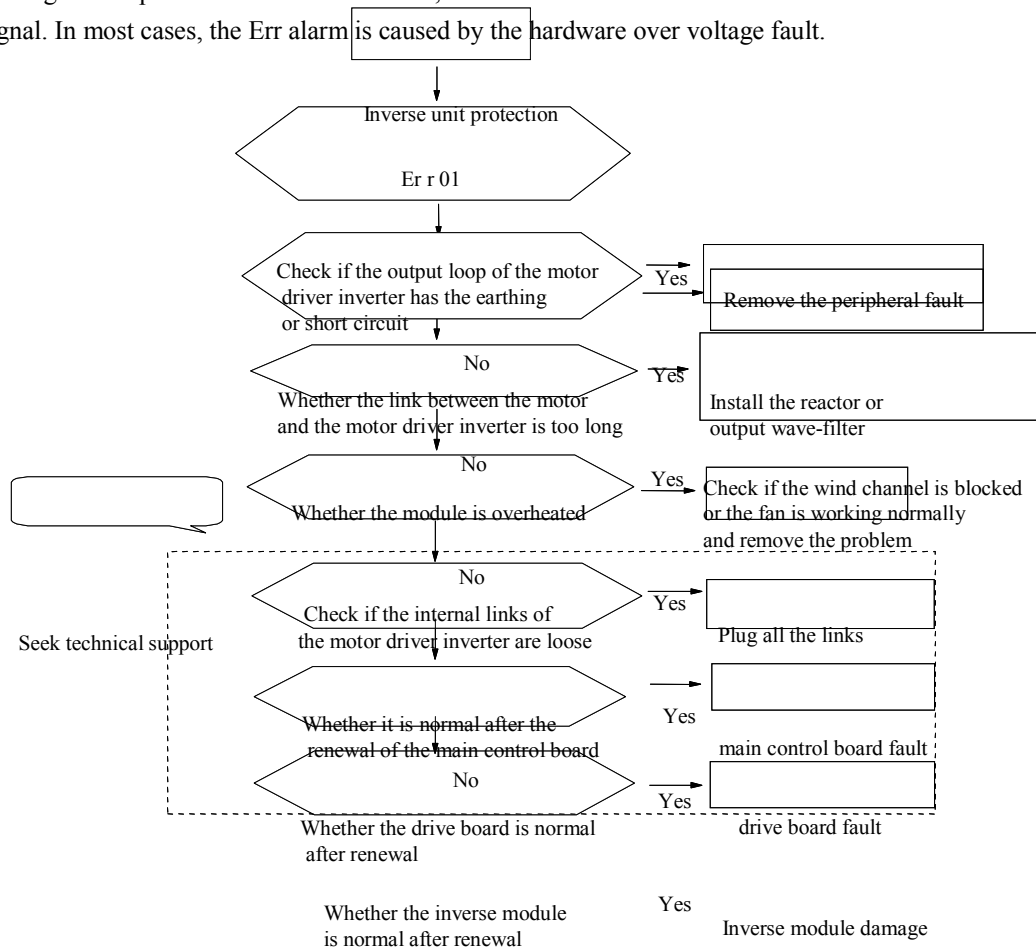



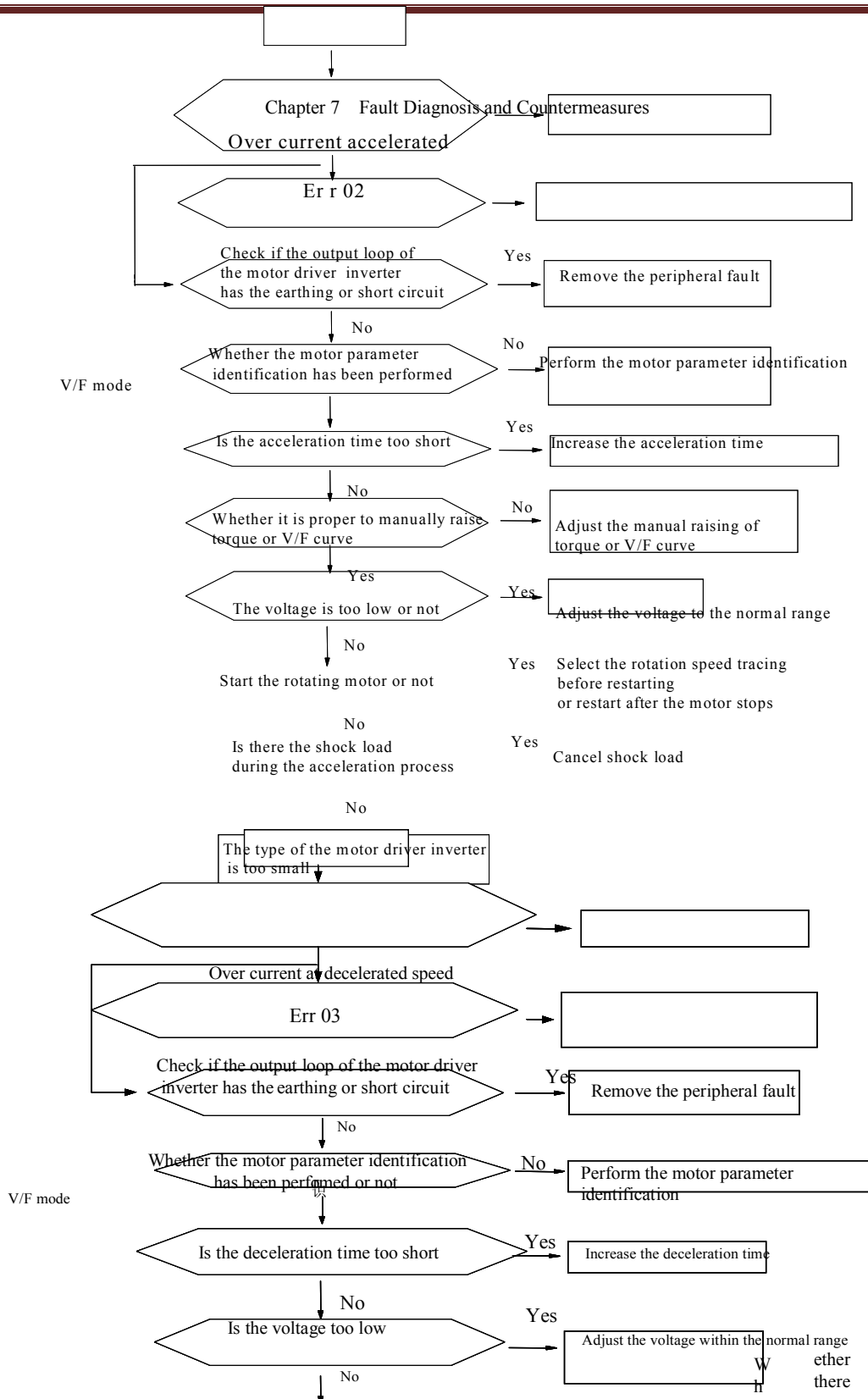

exists a shock load during the  
deceleration process

Yes

Cancel the shock load

Is there the brake unit or brake  
resistor installed

Install the brake unit and  
brake resistor

Seek for the technical support

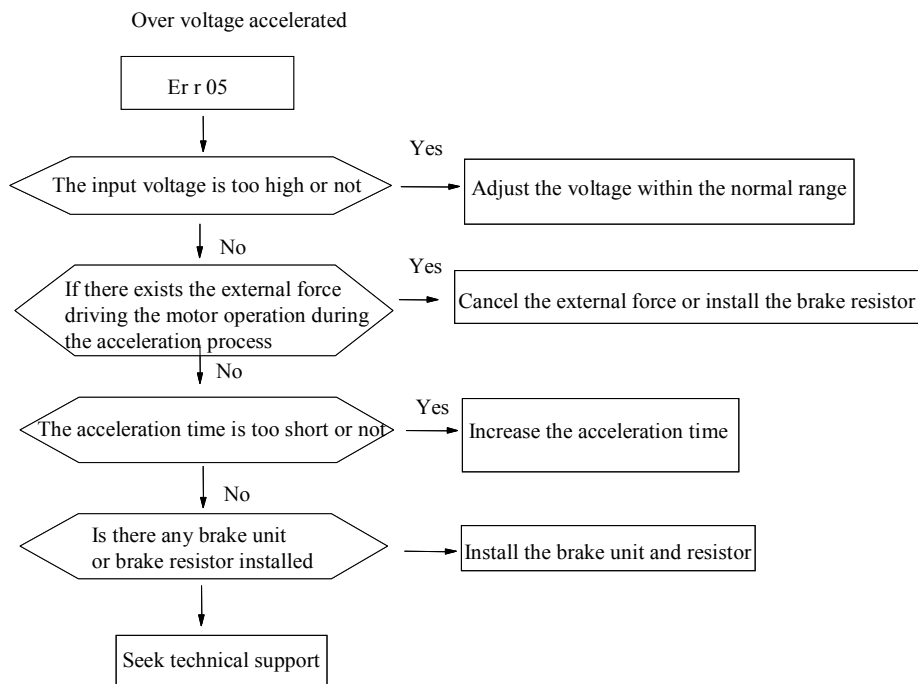
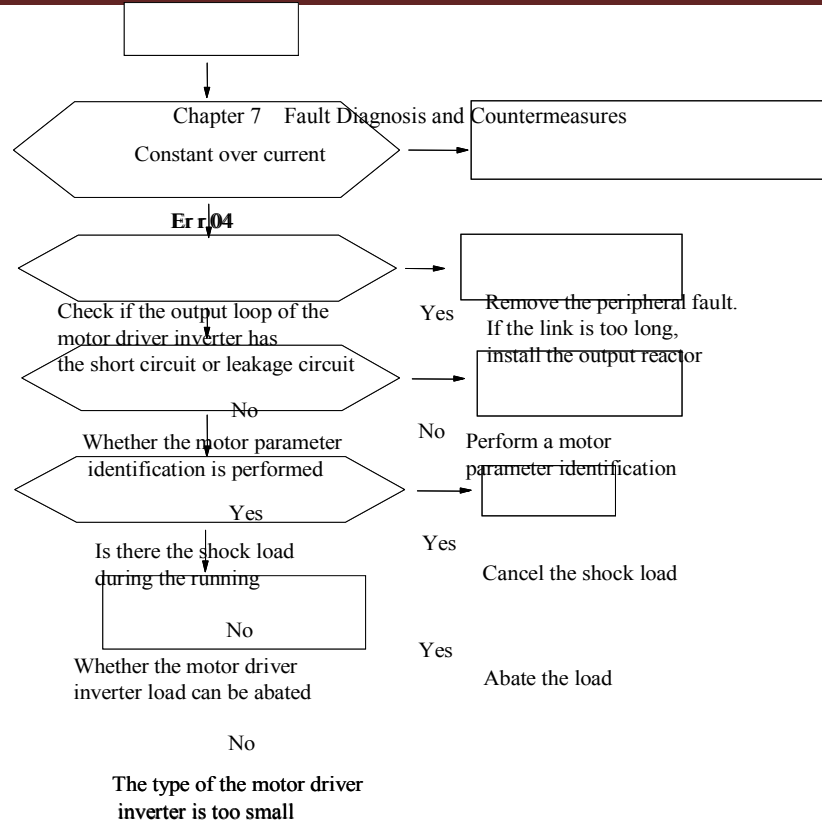



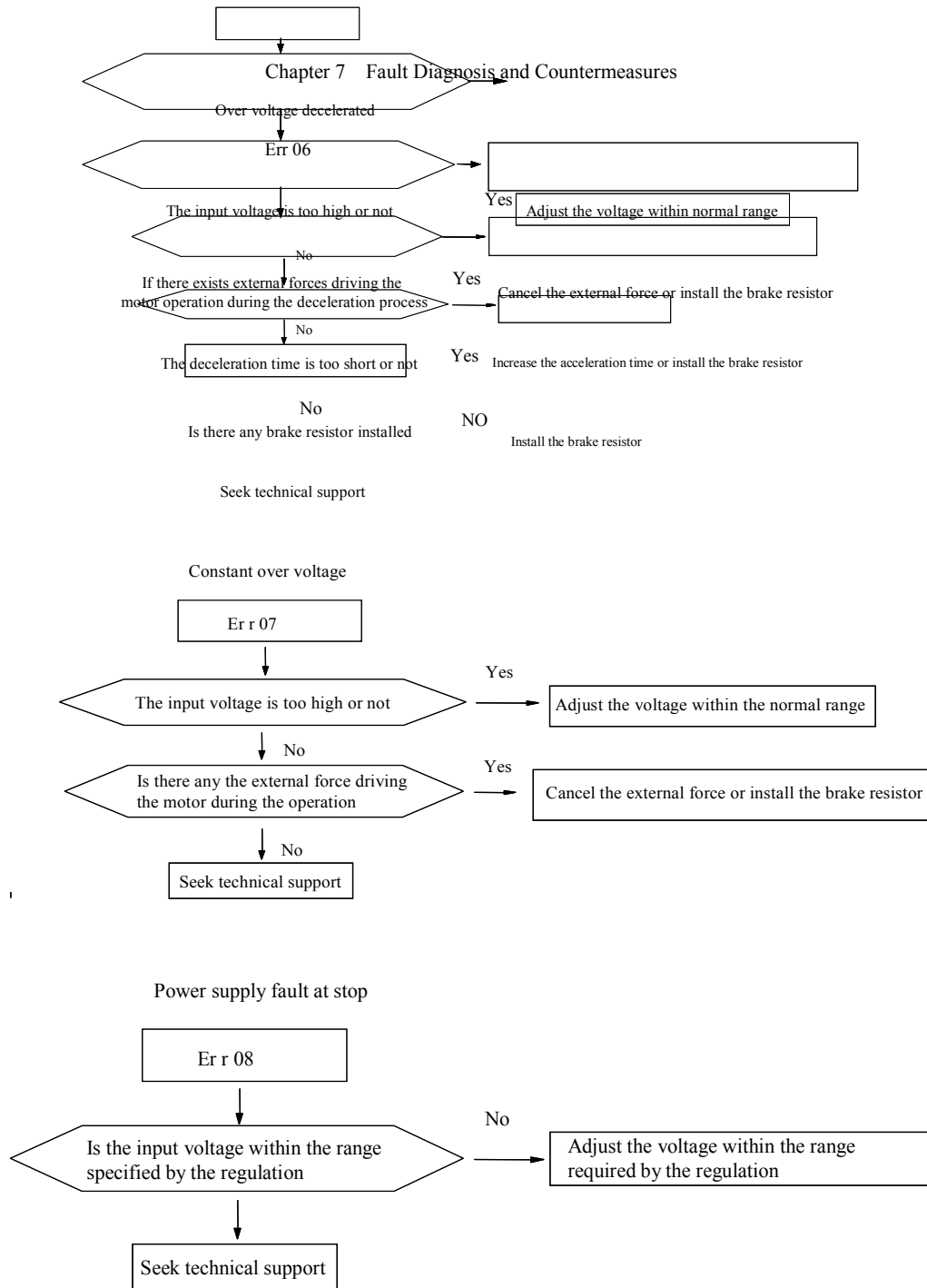





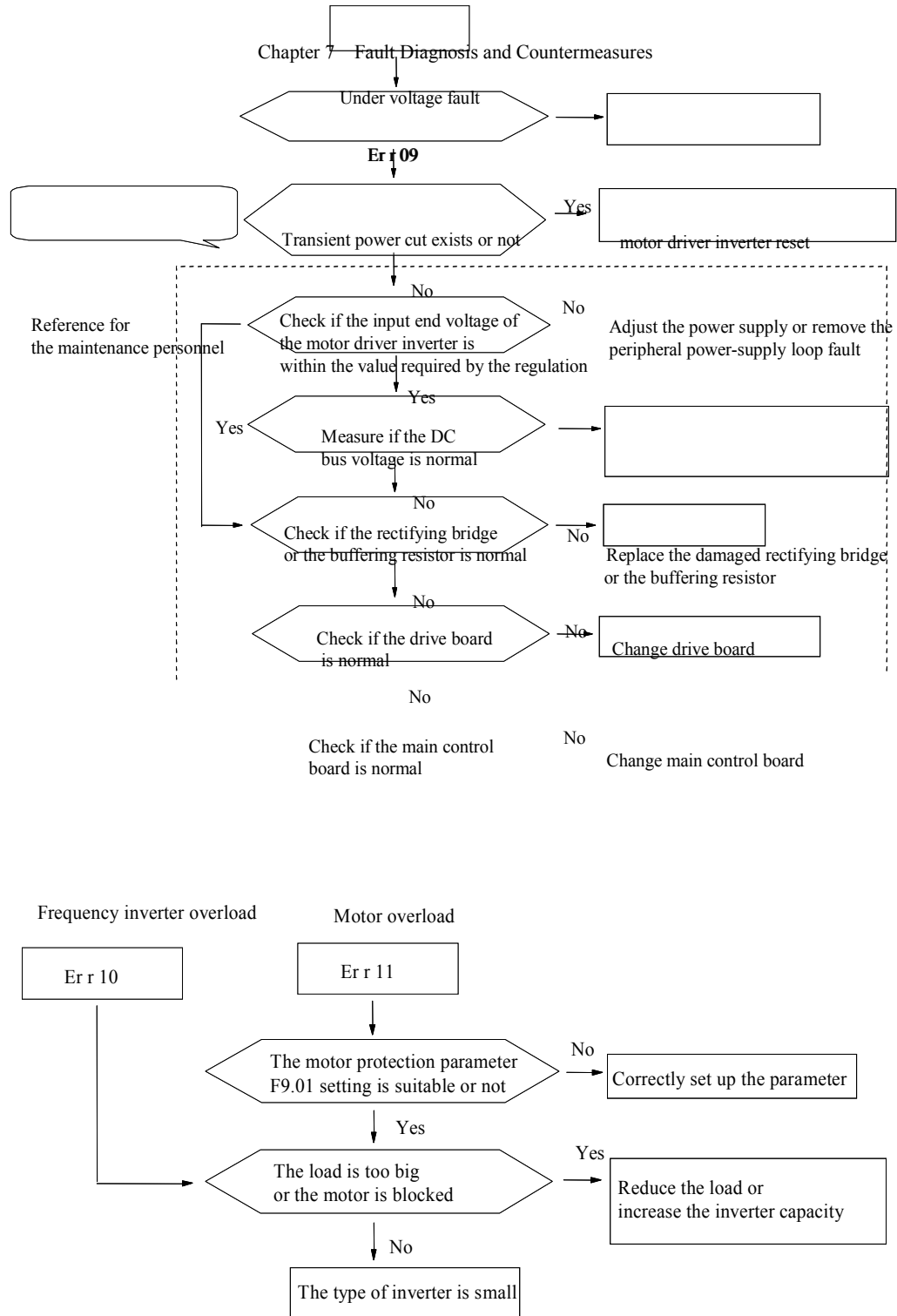



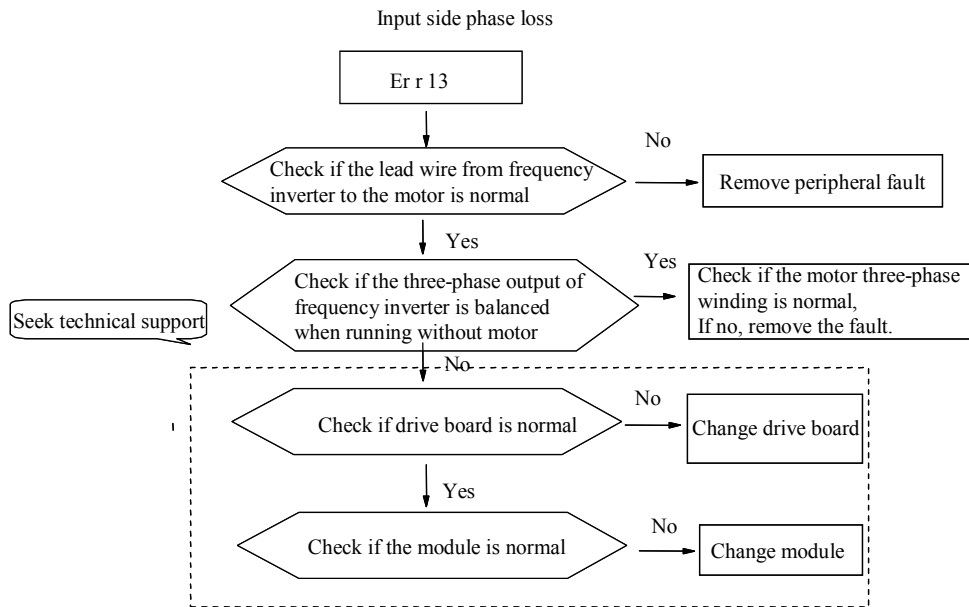
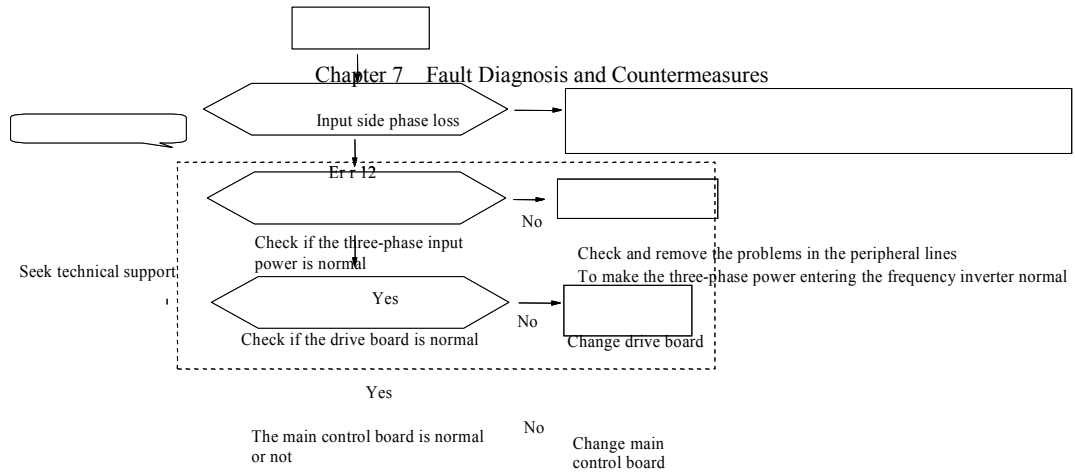



Chapter 7 Fault Diagnosis and Countermeasures

Module overheated

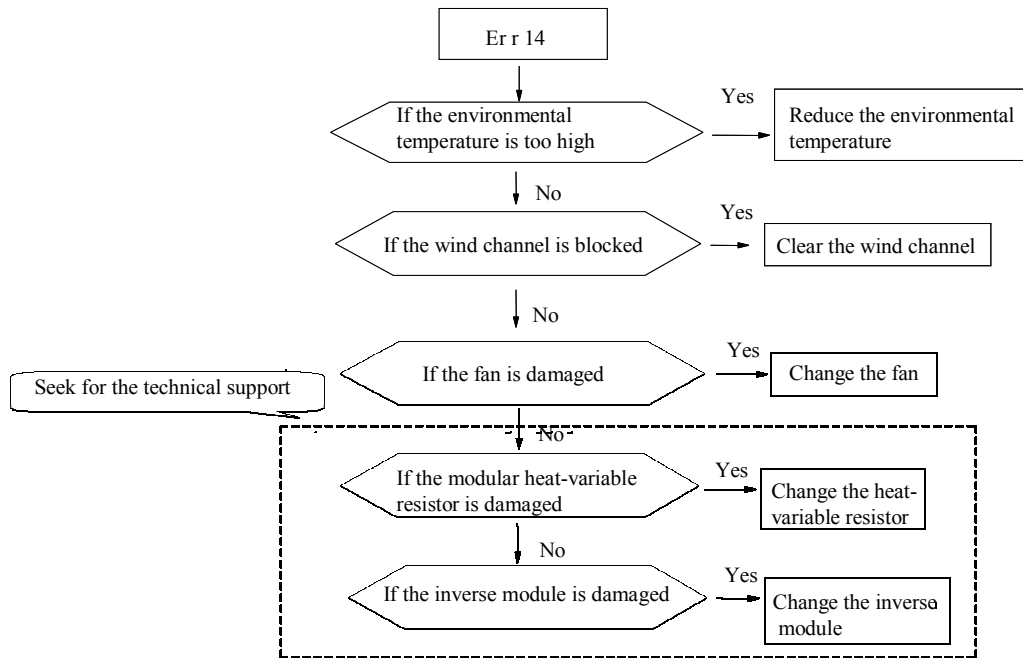

Peripheral equipment fault

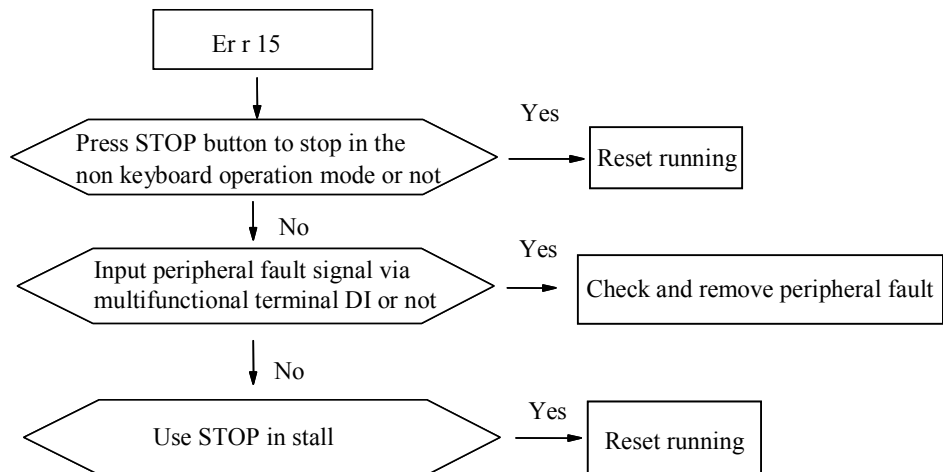

Current detection fault

Seek technical support

Err 18

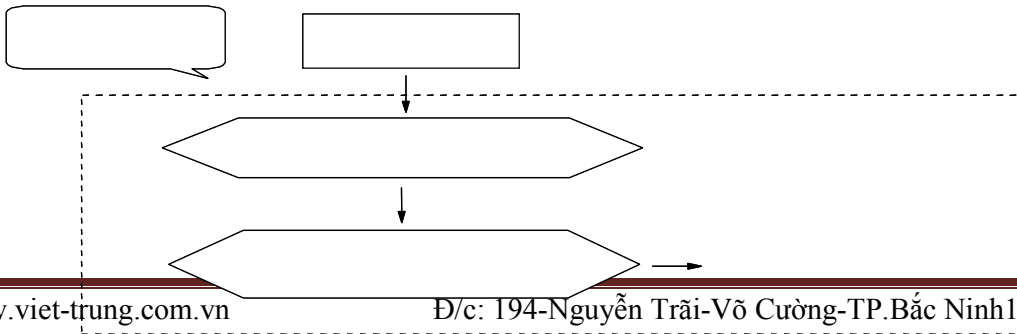
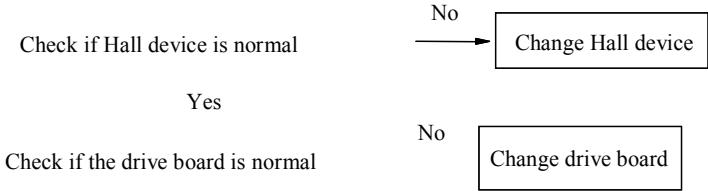

Chapter 7 Fault Diagnosis and Countermeasures

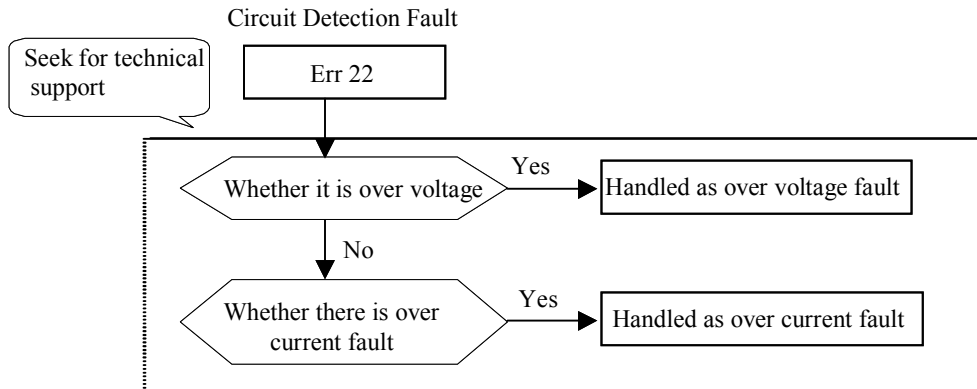
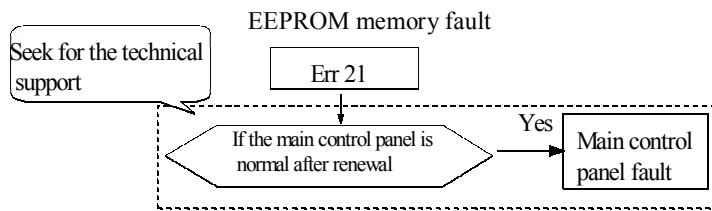
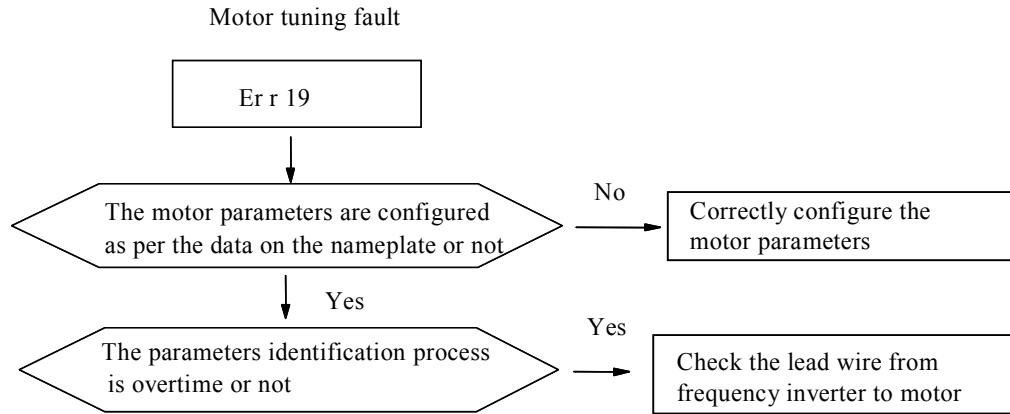

Earth short circuit fault

Err 23

Check whether the output is earth short-circuited Yes Change the drive board



No

Change cable or motor

79

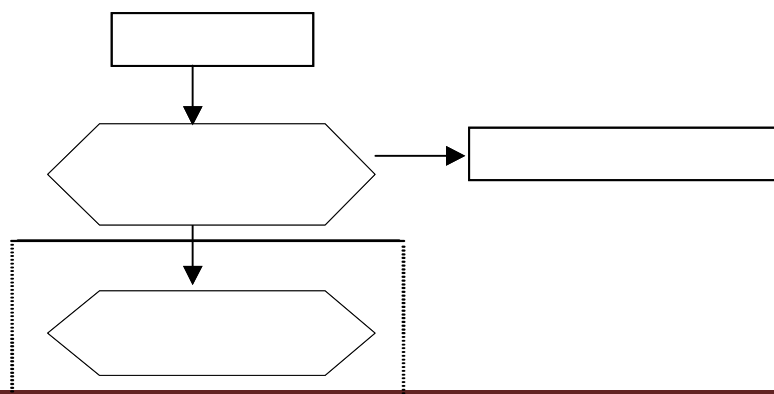

## 7.2 Common Faults and the Fault Diagnosis

The following faults may probably occur during the using of the inverter, please refer to the methods described below to perform the fault analysis.

### 1. No Electricity Display

- 1) Check with multimeter if the input power supply of the inverter is consistent with its rated voltage. If there is something wrong with the power supply, please check and remove it.
- 2) Check if the three-phase rectifying bridge is intact. If the rectifying bridge has been exploded, please seek technical service.
- 3) Check if the CHARGE indicator is on. If the indicator is off, the fault will be on the rectifying bridge or the buffering resistance. If the indicator is on, then the fault may probably lies in the switch on/off part, please seek for help.

### 3. The air Switch Trips off After Power-on

- 1) Check if the earthing or short circuit occurs between the input power supplies and remove the problem.
- 2) Check if the rectifying bridge has been broken down. If so, seek for the service.

### 4. The Motor Does not Run After the Inverter Starts to Run

- 1) Check if there is equalizing three-phase input between U, V and W. If yes, the motor circuit or itself may be damaged, or the motor stops turning for mechanical reason. Please remove it.

If there is input but the three phases are not equalizing, the inverter drive board or the output module may be damaged. Please seek for the service.

- 3) If there is no output voltage, the drive board or output module may be damaged. Please seek for the service.

### 5. When the Power-on Inverter Displays Normally, the Air Switch Trips off After the Operation.

- 1) Check if the short circuit occurs between the output modules. If yes, please seek the service.
- 2) Check if the short circuit or earthing occurs between the motor lead wires. If yes, please remove it.

- 3) If the tripping occurs only occasionally and the distance between the motor and the inverter is big, then the adding of an output AC reactor shall be considered.

## Warranty Agreement

1. Free warranty only applies to the inverter itself.
2. In normal circumstance, our company provides 18 months of warranty service (based on the bar code on the equipment) if the product is faulty or damaged. And reasonable fees should be charged for the maintenance once the warranty period is expired.
3. In the warranty period, we also charge certain maintenance fees for the following situations:
  - ⌘ Damages caused due to improper use against the specifications in the user manual.
  - ⌘ Damages caused because of fire disaster, flood disaster, abnormal voltage, etc.
  - ⌘ Damages caused when the inverter is applied abnormally
4. The service fee will be charged according to our company's unified standard. If the contract is signed, we will handle it according to the contract.
5. Be sure to keep this card and show it to the maintenance personnel when the warranty service is needed.
6. For any problems, please contact the local agent or our company directly.

Engineering Service Department of Shenzhen Inovance Technology Co., Ltd

Address: 1F, Office Building, Min Ning Garden, No.10, Cai Tian N. Rd. Fu Tian District, Shenzhen, China.

Tel: +86-755 83185929

+86-755 27589601/05

Fax: +86-755 83185929

+86-755 27589710

Zip code: 518036

Shenzhen Inovance Technology Co., Ltd.

<b>Warranty Card of the Inverter</b>	
User Company:	
Address:	
Zip code:	Contact person:
Tel:	Fax:
Equipment Model:	
Equipment Bar Code:	
Agent:	
1 <sup>st</sup> maintenance records (time and maintenance contents):	
Name of the maintenance personnel:	
2 <sup>nd</sup> maintenance records (time and maintenance contents):	

Name of the maintenance personnel:

C.TY TNHH TỰ ĐỘNG HÓA VIỆT TRUNG

02413.281.181-0989.984.666

---

---

Website: [www.viet-trung.com.vn](http://www.viet-trung.com.vn)

Đ/c: 194-Nguyễn Trãi-Võ Cường-TP.Bắc Ninh166

**Statement:**

- All rights reserved. Any unauthorized copy or plagiarism is prohibited.
- The information contained is subject to change without notice due to the continuous upgrade of the products by the manufacturer.