



# FRENIC 5000G11S

# FRENIC 5000P11S

**FUJI INVERTERS**

Now with dynamic torque vector control:  
Optimum control for all situations.



# I

deal combination of power and multiple-function.

Dynamic torque-vector control promises optimum motor control under any operating conditions.

## 1. Dynamic torque-vector control



Dynamic torque-vector control system performs high-speed calculation to determine the required motor power for the load status. Our key technology is optimal control of voltage and current vectors for maximum output torque.

- A high starting torque of 200% at 0.5Hz.\*  
\* 180% for 40HP or larger models.
- Achieves smooth acceleration/deceleration in the shortest time for the load condition.
- Using a high-speed CPU quickly responds to an abrupt load change, detects the regenerated power to control the deceleration time. This automatic deceleration function greatly reduces the inverter tripping.
- Feedback control with PG  
Enables the inverter to execute "vector control with PG" by adding an optional PG feedback card to obtain higher performance.
  - Speed control range : 1:1200
  - Speed control accuracy :  $\pm 0.02\%$
  - Speed control response : 40Hz

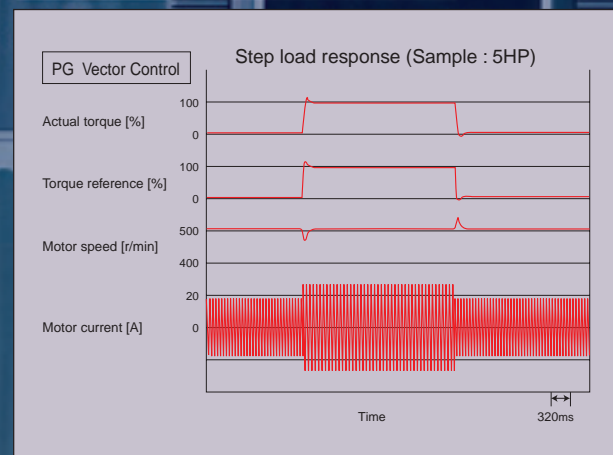
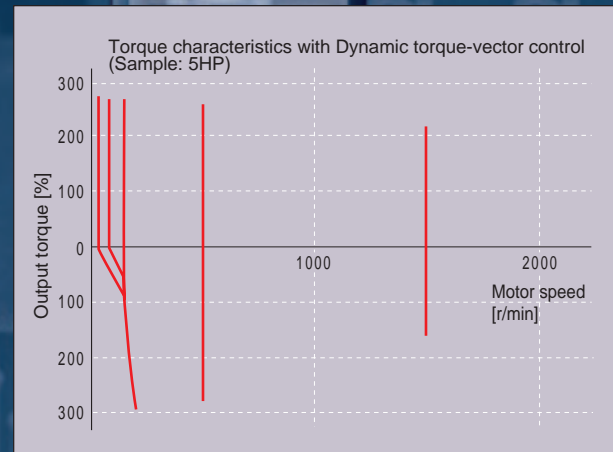

## 2. Reduced motor wow at low speed



- Motor wow at low speed (1Hz) reduced to less than 1/2 of that achieved by conventional inverters, with the dynamic torque-vector control system, in combination with the Fuji's unique digital AVR.

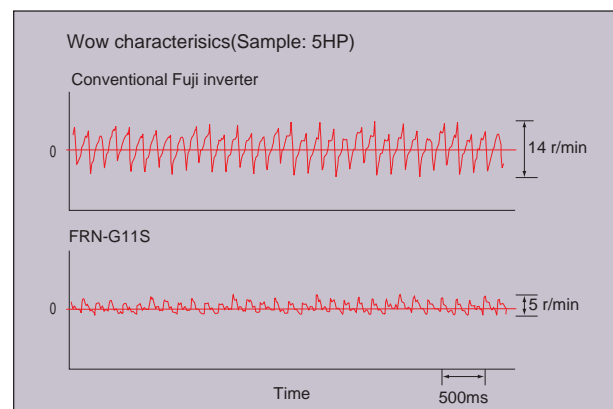

# G11S/P11S

## 3. New on-line tuning system



- On-line tuning to continuously check for variation of motor characteristics during running for high-precision speed control.
- This tuning function also available for a second motor, which allows high-precision driving of the second motor by changeover operation between two motors.

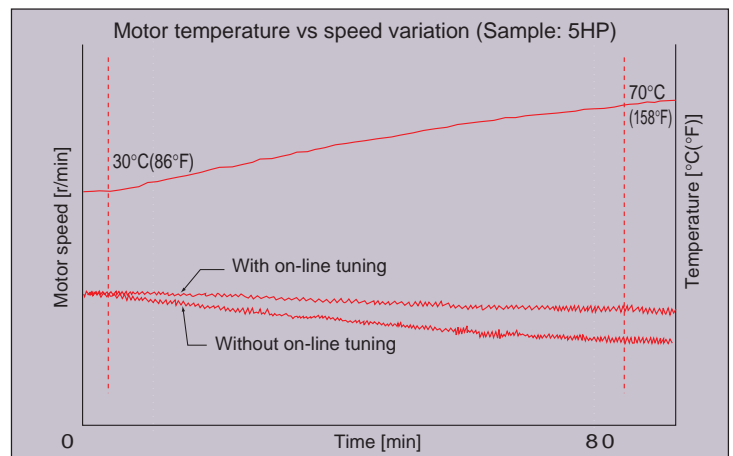

## 4. Environment-friendly features



- Provided with low-noise control power supply systems which minimize noise interference on peripheral devices such as sensors.
- Equipped with terminals for connecting DC REACTOR that can suppress harmonics.
- Complied with EMC Directive (Emission) when connected to optional EMC-compliance filter.

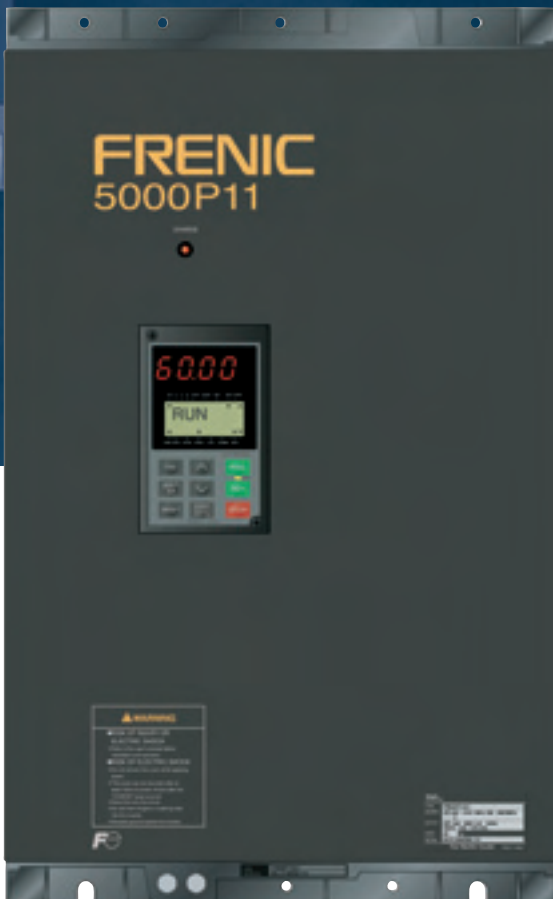

# G11S/P11S

## 5. Advanced, convenient functions



- 16-step speed with timer control, rotating motor pick-up control for conveyance machinery
- Automatic energy-saving operation, PID control, cooling fan on/off control, line/inverter changeover operation for fans and pumps
- Rotating motor pick-up control:  
Restarts motor without any shocks, by detecting motor speed where motor is coasting after momentary power failure occurs.
- Automatic energy-saving operation function:  
Minimizes inverter and motor loss at light load.

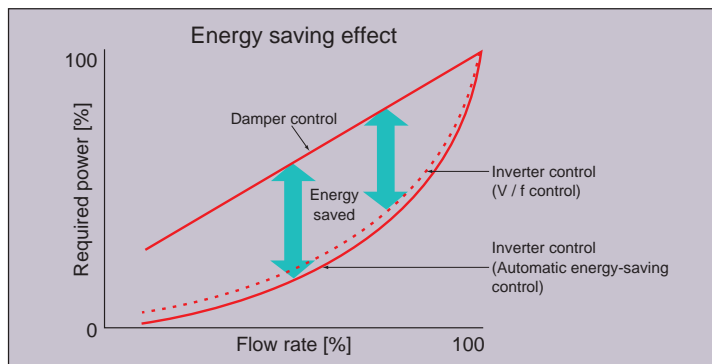
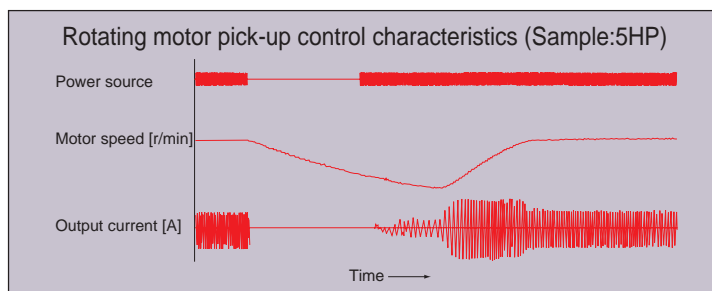

## 6. Global products, communication



- Conforms to major world safety standards: UL, cUL, TÜV (up to 30HP), EN (CE marking)
- Equipped with RS-485 interface as standard.
- Connection to field bus: PROFIBUS-DP, Interbus-S, DeviceNet, Modbus Plus (Option)
- Universal DI/DO : Monitors digital I/O signal status and transmits to a host controller, helping to simplify factory automation.



### Safety Precautions

1. Use the contents of this catalog only for selecting product types and models. When using a product, read the Instruction Manual beforehand to use the product correctly.
2. Products introduced in this catalog have not been designed or manufactured for such applications in a system or equipment that will affect human bodies or lives. Customers, who want to use the products introduced in this catalog for special systems or devices such as for atomic-energy control, aerospace use, medical use, and traffic control, are requested to consult the Fuji's Sales Division. Customers are requested to prepare safety measures when they apply the products introduced in this catalog to such systems or facilities that will affect human lives or cause severe damage to property if the products become faulty.

## 7. Intelligent Keypad panel



- Copy function: Easily copies function codes and data to other inverters.
- Six languages (English, French, German, Italian, Spanish, and Japanese) are available as standard.
- Jogging (inching) operation from the Keypad or external signal
- Remote operation using optional extension cable (CBIII-10R-□□□□)



## 8. Protective functions, Maintenance



### Protection

- Motors with various characteristics can be used by setting thermal time constant for the electronic thermal overload protection.
- Input phase loss protective function protects the inverter from damage caused by disconnection of power supply lines.
- Motor is protected with a PTC thermistor.
- Input terminals for auxiliary control power supply (2HP or larger models) : Alarm signal output will be held even if main circuit power supply has shut down.

### Excellent maintainability

The items below can be monitored on the Keypad panel and making it easy to analyze the cause of trip and to take preventive measures.

- Input/output terminals check
- Life expectancy of main-circuit capacitors
- Inverter on-load factor
- Accumulated operation time
- Inverter operating condition (output current, heat sink temperature, input power, etc.)
- Detailed data on trip cause

## 9. Extensive product line



- Two series are available: G11S series ranging from 1/4 to 600HP for general industrial machines and P11S series ranging from 7.5 to 800HP for fans and pumps.
- Totally-enclosed casing (NEMA1) (up to 30HP as standard).
- Optional NEMA1 enclosure available for 40HP or larger models.

## 10. Other useful functions

- Side-by-side mounting (up to 30HP) saves space when inverters are installed in a panel.
- The uniform height (10.24inch(260mm)) of products (up to 10HP) makes it easy to design panels.
- User-definable control terminals: Digital input (9 points), transistor output (4points), and relay contact output (1point).
- Active drive feature: Performs prolonged acceleration at reduced torque, monitoring the load status to prevent tripping.
- Stall prevention function is provided as standard. Active or inactive can be also selected.

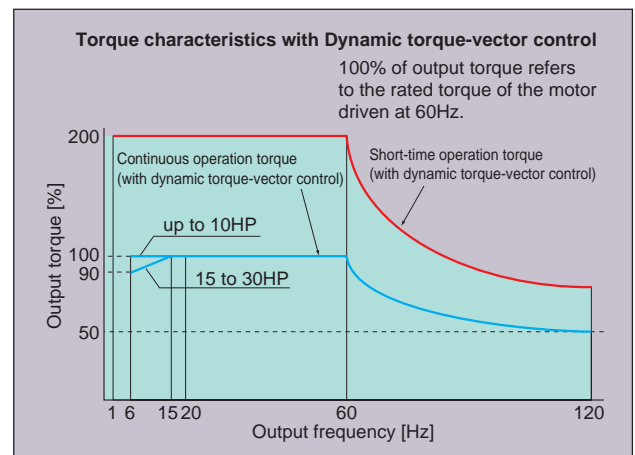

\* The above graph shows an example of torque characteristics when combining FRENIC5000G11S (up to 30HP at dynamic torque-vector control) with Fuji standard three-phase motor (8-type series, 4 poles). Continuous operation torque is for limits of allowable load torque for using the motor within the allowable temperature range and is not for motor output torque.

The motor output torque is shown by the short-time operation torque.

# Variation

Easy to apply to customer systems. A consistent design concept in all models from 1/4HP to 800HP.

Nominal applied motors [HP]	FRENIC5000G11S series for general industrial machines		FRENIC5000P11S series for fans and pumps (variable torque loads)	
	230V	460V	230V	460V
1/4	FRNF25G11S-2UX			
1/2	FRNF50G11S-2UX	FRNF50G11S-4UX		
1	FRN001G11S-2UX	FRN001G11S-4UX		
2	FRN002G11S-2UX	FRN002G11S-4UX		
3	FRN003G11S-2UX	FRN003G11S-4UX		
5	FRN005G11S-2UX	FRN005G11S-4UX		
7.5	FRN007G11S-2UX	FRN007G11S-4UX	FRN007P11S-2UX	FRN007P11S-4UX
10	FRN010G11S-2UX	FRN010G11S-4UX	FRN010P11S-2UX	FRN010P11S-4UX
15	FRN015G11S-2UX	FRN015G11S-4UX	FRN015P11S-2UX	FRN015P11S-4UX
20	FRN020G11S-2UX	FRN020G11S-4UX	FRN020P11S-2UX	FRN020P11S-4UX
25	FRN025G11S-2UX	FRN025G11S-4UX	FRN025P11S-2UX	FRN025P11S-4UX
30	FRN030G11S-2UX	FRN030G11S-4UX	FRN030P11S-2UX	FRN030P11S-4UX
40	FRN040G11S-2UX	FRN040G11S-4UX	FRN040P11S-2UX	FRN040P11S-4UX
50	FRN050G11S-2UX	FRN050G11S-4UX	FRN050P11S-2UX	FRN050P11S-4UX
60	FRN060G11S-2UX	FRN060G11S-4UX	FRN060P11S-2UX	FRN060P11S-4UX
75	FRN075G11S-2UX	FRN075G11S-4UX	FRN075P11S-2UX	FRN075P11S-4UX
100	FRN100G11S-2UX	FRN100G11S-4UX	FRN100P11S-2UX	FRN100P11S-4UX
125	FRN125G11S-2UX	FRN125G11S-4UX	FRN125P11S-2UX	FRN125P11S-4UX
150		FRN150G11S-4UX	FRN150P11S-2UX	FRN150P11S-4UX
200		FRN200G11S-4UX		FRN200P11S-4UX
250		FRN250G11S-4UX		FRN250P11S-4UX
300		FRN300G11S-4UX		FRN300P11S-4UX
350		FRN350G11S-4UX		FRN350P11S-4UX
400		FRN400G11S-4UX		FRN400P11S-4UX
450		FRN450G11S-4UX		FRN450P11S-4UX
500		FRN500G11S-4UX		FRN500P11S-4UX
600		FRN600G11S-4UX		FRN600P11S-4UX
700				FRN700P11S-4UX
800				FRN800P11S-4UX

# FRENIC 5000G1 industrial plant

## Fans

- Air-conditioning system (for factory, building, office, hospital, clean room, shop, and cattle barn)
- Dryer
- Boiler fan
- Fans for controlling furnace temperature
- Roof fans controlled as a group
- Refrigerator
- Compressor
- Built-in blower in a film-manufacturing machine
- Cooling-tower fans
- Ventilating fans
- Air-conditioning equipment

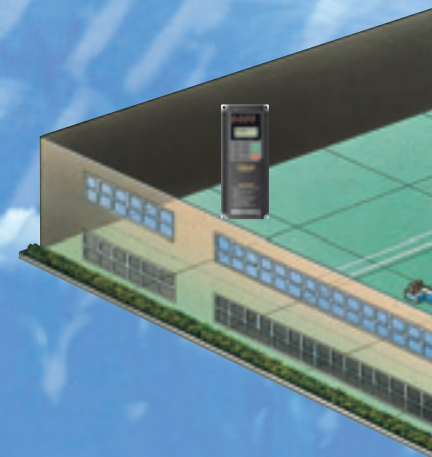

## How to read the model number

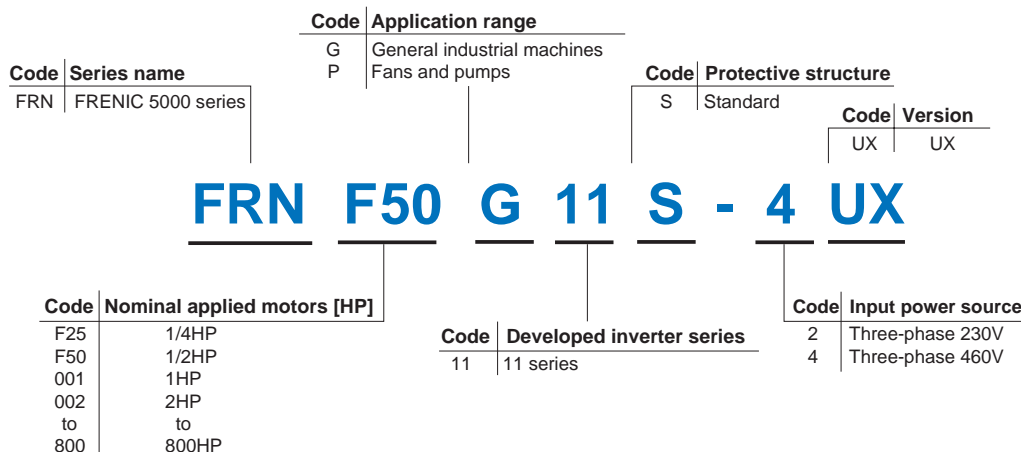

## Food processing machines

- Food mixing machine
- Food slicer
- Grain milling machine (bread, cake, noodles)
- Tea making machine
- Rice cleaning machine

# 1S/P11S can be used for almost all and equipment areas.

## Machine tools

- Grinding machine
- Sanding machine
- Milling machine
- Lathe
- Drilling machine
- Turntable
- Work positioning machine
- PC board drilling machine
- Winding machine
- Press

## Conveyance machinery

- Crane (traveling, traversing, hoisting)
- Automated warehouse
- Conveyor (belt, chain, screw, roller)
- Lift
- Car parking facility
- Elevator, escalator
- Automatic door
- Shutter equipment
- Speed-change gear

## Chemical machinery/wood working machines

- Fluid mixing machine
- Extruder
- Vibrator
- Centrifugal separator
- Coating machine
- Take-up roller
- Routing machine
- Sanding machine
- Planing machine

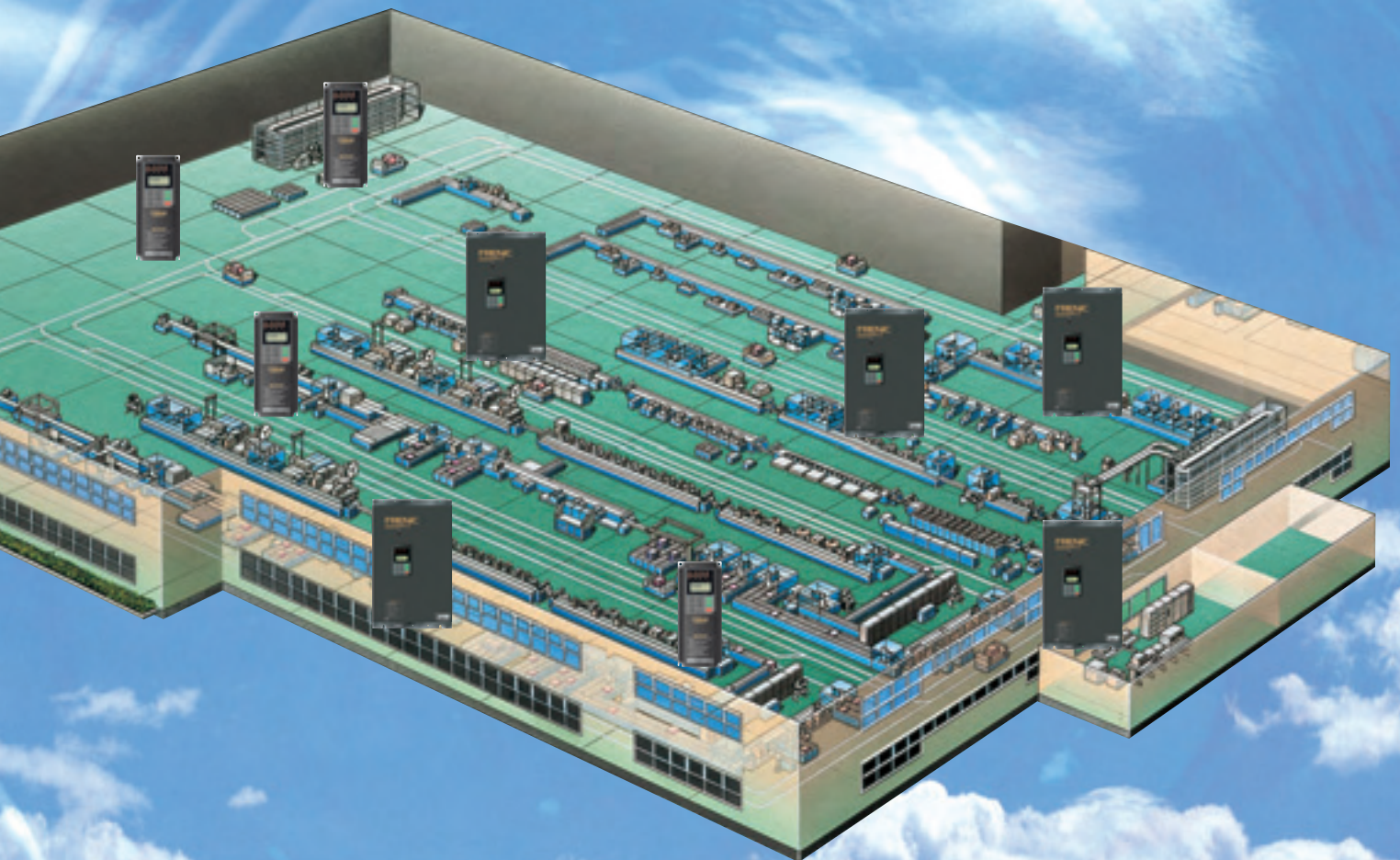

## Electric pumps

- Tankless water supply system
- Submersible motor pump
- Vacuum pump
- Fountain pump
- Cooling water pump
- Circulating hot water pump
- Well pump
- Agricultural storage pump
- Water treatment system
- Constant-flow pump
- Sludge pump

## Packaging machinery

- Individual packaging/inner-packaging machine
- Packing machine
- Outer-packaging machine

## Paper making/ textile machinery

- Spinning machine
- Knitting machine
- Textile printing machine
- Industrial sewing machine
- Synthetic fiber manufacturing plant

## Other machinery

- Automated feed/medicine mixer
- Commercial-use washing machine
- Offset printing press
- Book-binding machine
- Car-washing machine
- Shredder
- Dishwasher
- Test equipment
- Crusher

# Standard Specifications

## FRENIC5000G11S 230V, for general industrial machines

Type	FRN	G11S-2UX	F25	F50	001	002	003	005	007	010	015	020	025	030	040	050	060	075	100	125												
<b>Nominal applied motor</b>			<b>HP</b>																													
<b>Output ratings</b>	<b>Rated capacity *1)</b>		<b>kVA</b>																													
	<b>Rated voltage *2)</b>		<b>V</b>																													
	<b>Rated current *3)</b>		<b>A</b>																													
	<b>Overload capability</b>		150% of rated current for 1min. 200% of rated current for 0.5s												150% of rated current for 1min. 180% of rated current for 0.5s																	
	<b>Rated frequency</b>		<b>Hz</b>																													
<b>Input ratings</b>	<b>Phases, Voltage, Frequency</b>		3-phase 200 to 230V 50/60Hz												3-phase 200 to 220V/50Hz (220 to 230V/50Hz) *5) 200 to 230V/60Hz																	
	<b>Voltage / frequency variations</b>		Voltage : +10 to -15% ( Voltage unbalance *6) : 2% or less ) Frequency : +5 to -5%																													
	<b>Momentary voltage dip capability *7)</b>		When the input voltage is 165V or more, the inverter can be operated continuously. When the input voltage drops below 165V from rated voltage, the inverter can be operated for 15ms . The smooth recovery method is selectable.																													
	<b>Rated current *8)</b> (with DCR)		<b>A</b>																													
	<b>Required power supply capacity *9)</b>		<b>kVA</b>																													
<b>Control</b>	<b>Starting torque</b>		200% (with Dynamic torque-vector control selected)												180% (with Dynamic torque-vector control selected)																	
<b>Braking</b>	<b>Standard</b>	<b>Braking torque</b>	150%						100%						20% *10)						10 to 15% *10)											
		<b>Time</b>	s						5						No limit																	
		<b>Duty cycle</b>	%						5						3						2											
	<b>Braking torque (Using options)</b>		150%												100%																	
	<b>DC injection braking</b>		Starting frequency: 0.1 to 60.0Hz Braking time: 0.0 to 30.0s Braking level: 0 to 100% of rated current																													
<b>Enclosure (IEC 60529)</b>			Natural cooling												IP 40 (NEMA1)						Fan cooling						IP 00 ( NEMA1: Option )					
<b>Cooling method</b>																																
<b>Standards</b>			-UL/cUL -Low Voltage Directive -EMC Directive TÜV (up to 30HP) -IEC 61800-2 (Ratings, specifications for low voltage adjustable frequency a.c. power drive systems) -IEC 61800-3 (EMC product standard including specific test methods)																													
<b>Weight</b>			<b>lbs(kg)</b>																													

## FRENIC5000G11S 460V, for general industrial machines

Type	FRN	G11S-4UX	F50	001	002	003	005	007	010	015	020	025	030	040	050	060	075	100	125	150	200	250	300	350	400	450	500	600	
<b>Nominal applied motor</b>			<b>HP</b>																										
<b>Output ratings</b>	<b>Rated capacity *1)</b>		<b>kVA</b>																										
	<b>Rated voltage *2)</b>		<b>V</b>																										
	<b>Rated current *3)</b>		<b>A</b>																										
	<b>Overload capability</b>		150% of rated current for 1min. 200% of rated current for 0.5s															150% of rated current for 1min. 180% of rated current for 0.5s											
	<b>Rated frequency</b>		<b>Hz</b>																										
<b>Input ratings</b>	<b>Phases, Voltage, Frequency</b>		3-phase 380 to 480V 50/60Hz															3-phase 380 to 440V/50Hz 380 to 480V/60Hz *4)											
	<b>Voltage / frequency variations</b>		Voltage : +10 to -15% ( Voltage unbalance *6) : 2% or less ) Frequency : +5 to -5%																										
	<b>Momentary voltage dip capability *7)</b>		When the input voltage is 310V or more, the inverter can be operated continuously. When the input voltage drops below 310V from rated voltage, the inverter can be operated for 15ms. The smooth recovery method is selectable.																										
	<b>Rated current *8)</b> (with DCR)		<b>A</b>																										
	<b>Required power supply capacity *9)</b>		<b>kVA</b>																										
<b>Control</b>	<b>Starting torque</b>		200% (with Dynamic torque-vector control selected)															180% (with Dynamic torque-vector control selected)											
<b>Braking</b>	<b>Standard</b>	<b>Braking torque</b>	150%						100%						20% *10)						10 to 15% *10)								
		<b>Time</b>	s						5						No limit														
		<b>Duty cycle</b>	%						5						3						2								
	<b>Braking torque (Using options)</b>		150%															100%											
	<b>DC injection braking</b>		Starting frequency: 0.1 to 60.0Hz Braking time: 0.0 to 30.0s Braking level: 0 to 100% of rated current																										
<b>Enclosure (IEC 60529)</b>			IP 40 (NEMA1)															IP 00 ( NEMA1: Option )											
<b>Cooling method</b>			Natural cooling															Fan cooling											
<b>Standards</b>			-UL/cUL -Low Voltage Directive -EMC Directive TÜV (up to 30HP) -IEC 61800-2 (Ratings, specifications for low voltage adjustable frequency a.c. power drive systems) -IEC 61800-3 (EMC product standard including specific test methods)																										
<b>Weight</b>			<b>lbs(kg)</b>																										

NOTES: \*1) Inverter output capacity (kVA) at 460V in 460V, 230V in 230V. \*2) Output voltage is proportional to the power supply voltage and cannot exceed the power supply voltage. \*3) Current derating may be required in case of low impedance loads such as high frequency motor. \*4) When the input voltage is 380V/50Hz or 380 to 415V/60Hz, the tap of the auxiliary transformer must be changed. \*5) Order individually. \*6) Refer to the IEC 61800-3( 5.2.3 ). \*7) Tested at standard load condition (85% load). \*8) This value is under FUJI original calculation method. (Refer to the Technical Information.) \*9) When power-factor correcting DC reactor is used. \*10) With a nominal applied motor, this value is average torque when the motor decelerates and stops from 60Hz. (It may change according to motor loss.)



## FRENIC5000P11S 230V, for fans and pumps

Type	FRN	P11S-2UX	007	010	015	020	025	030	040	050	060	075	100	125	150		
Nominal applied motor		HP	7.5	10	15	20	25	30	40	50	60	75	100	125	150		
Output ratings	Rated capacity *1)		kVA	8.8	12	17	22	27	31	46	58	72	86	113	138	165	
	Rated voltage *2)		V	3-phase 200V/50Hz 200, 220V, 230V/60Hz													
	Rated current *3)		A	22	29	42	55	67	78	115	145	180	215	283	346	415	
	Overload capability			110% of rated current for 1min													
Rated frequency		Hz	50, 60Hz														
Input ratings	Phases, Voltage, Frequency			3-phase 200 to 230V 50/60Hz						3-phase 200 to 220V/50Hz (220 to 230V/50Hz) *5)						200 to 230V/60Hz	
	Voltage / frequency variations			Voltage : +10 to -15% ( Voltage unbalance *6) : 2% or less ) Frequency :+5 to -5%													
	Momentary voltage dip capability *7)			When the input voltage is 165V or more, the inverter can be operated continuously. When the input voltage drops below 165V from rated voltage, the inverter can be operated for 15ms . The smooth recovery method is selectable.													
	Rated current *8)		(with DCR)	19.7	26.9	39.0	54.0	66.2	78.8	109	135	163	199	272	327	400	
		(without DCR)	40.8	52.6	76.9	98.5	117	136	168	204	243	291	-	-	-		
Required power supply capacity *9)		kVA	6.9	9.4	14	19	23	28	38	47	57	69	95	114	139		
Control	Starting torque		50%														
Braking	Standard	Braking torque *10)		20%						10 to 15%							
		Time	s No limit														
	Duty cycle		%														
	Braking torque (Using options)		100%						70%								
DC injection braking		Starting frequency: 0.1 to 60.0Hz Braking time: 0.0 to 30.0s Braking level: 0 to 80% of rated current															
Enclosure (IEC 60529)		IP 40 (NEMA1)						IP 00 ( NEMA1 : Option )									
Cooling method		Fan cooling															
Standards		-UL/cUL -Low Voltage Directive -EMC Directive TÜV (up to 30HP) -IEC 61800-2 (Ratings, specifications for low voltage adjustable frequency a.c. power drive systems) -IEC 61800-3 (EMC product standard including specific test methods)															
Weight	lbs(kg)		12.6 (5.7)	12.6 (5.7)	12.6 (5.7)	22 (10)	22 (10)	23.1 (10.5)	63.9 (29)	63.9 (29)	79.4 (36)	97 (44)	101.4 (46)	154.3 (70)	253.5 (115)		

## FRENIC5000P11S 460V, for fans and pumps

Type	FRN	P11S-4UX	007	010	015	020	025	030	040	050	060	075	100	125	150	200	250	300	350	400	450	500	600	700	800		
Nominal applied motor		HP	7.5	10	15	20	25	30	40	50	60	75	100	125	150	200	250	300	350	400	450	500	600	700	800		
Output ratings	Rated capacity *1)		kVA	10	13	18	24	29	35	48	60	72	89	119	140	167	201	242	300	330	386	414	517	589	668	764	
	Rated voltage *2)		V	3-phase 380, 400, 415V/50Hz 380, 400, 440, 460V/60Hz																							
	Rated current *3)		A	12.5	16.5	23	30	37	44	60	75	91	112	150	176	210	253	304	377	415	485	520	650	740	840	960	
	Overload capability			110% of rated current for 1min																							
Rated frequency		Hz	50, 60Hz																								
Input ratings	Phases, Voltage, Frequency			3-phase 380 to 480V 50/60Hz						3-phase 380 to 440V/50Hz 380 to 480V/60Hz *4)																	
	Voltage / frequency variations			Voltage : +10 to -15% ( Voltage unbalance *6) : 2% or less ) Frequency :+5 to -5%																							
	Momentary voltage dip capability *7)			When the input voltage is 310V or more, the inverter can be operated continuously. When the input voltage drops below 310V from rated voltage, the inverter can be operated for 15ms. The smooth recovery method is selectable.																							
	Rated current *8)		(with DCR)	10.0	13.5	19.8	26.8	33.2	39.3	54	67	81	100	134	160	196	232	282	352	385	491	552	624	704	792	880	
		(without DCR)	21.5	27.9	39.1	50.3	59.9	69.3	86	104	124	150	-	-	-	-	-	-	-	-	-	-	-	-	-		
Required power supply capacity *9)		kVA	7.0	9.4	14	19	24	28	38	47	57	70	93	111	136	161	196	244	267	341	383	433	488	549	610		
Control	Starting torque		50%																								
Braking	Standard	Braking torque *10)		20%						10 to 15%																	
		Time	s No limit																								
	Duty cycle		%																								
	Braking torque (Using options)		100%						70%																		
DC injection braking		Starting frequency: 0.1 to 60.0Hz Braking time: 0.0 to 30.0s Braking level: 0 to 80% of rated current																									
Enclosure (IEC 60529)		IP 40 (NEMA1)						IP 00 ( NEMA1 : Option )																			
Cooling method		Fan cooling																									
Standards		-UL/cUL -Low Voltage Directive -EMC Directive TÜV (up to 30HP) -IEC 61800-2 (Ratings, specifications for low voltage adjustable frequency a.c. power drive systems) -IEC 61800-3 (EMC product standard including specific test methods)																									
Weight	lbs(kg)		13.4 (6.1)	13.4 (6.1)	13.4 (6.1)	22 (10)	22 (10)	23.1 (10.5)	63.9 (29)	63.9 (29)	75 (34)	86 (39)	88.2 (40)	105.8 (48)	154.3 (70)	154.3 (70)	220.5 (100)	220.5 (100)	308.6 (140)	308.6 (140)	308.6 (140)	551.2 (250)	551.2 (250)	793.7 (360)	793.7 (360)		

NOTES: \*1) Inverter output capacity (kVA) at 460V in 460V, 230V in 230V. \*2) Output voltage is proportional to the power supply voltage and cannot exceed the power supply voltage. \*3) Current derating may be required in case of low impedance loads such as high frequency motor. \*4) When the input voltage is 380V/50Hz or 380 to 415V/60Hz, the tap of the auxiliary transformer must be changed. \*5) Order individually. \*6) Refer to the IEC 61800-3( 5.2.3 ). \*7) Tested at standard load condition (85% load). \*8) This value is under FUJI original calculation method. (Refer to the Technical Information.) \*9) When power-factor correcting DC reactor (DCR) is used. \*10) With a nominal applied motor, this value is average torque when the motor decelerates and stops from 60Hz. (It may change according to motor loss.)

# Common Specifications

Item		Explanation		
		G11S	P11S	
Output frequency	Setting	Maximum frequency	50 to 400Hz	50 to 120Hz
		Base frequency	25 to 400Hz	25 to 120Hz
		Starting frequency	0.1 to 60Hz, Holding time: 0.0 to 10.0s	
		Carrier frequency *1)	0.75 to 15kHz (75HP or smaller) 0.75 to 10kHz (100HP or larger)	0.75 to 15kHz (30HP or smaller) 0.75 to 10kHz (40 to 100HP) 0.75 to 6kHz (125HP or larger)
	Accuracy (Stability)	<ul style="list-style-type: none"> <li>Analog setting : ±0.2% of Maximum frequency (at 25±10°C(77±50°F))</li> <li>Digital setting : ±0.01% of Maximum frequency (at -10 to +50°C(14 to 122°F))</li> </ul>		
Setting resolution	<ul style="list-style-type: none"> <li>Analog setting : 1/1000 of Maximum frequency ex.) 0.06Hz at 60Hz, 0.12Hz at 120Hz, (0.4Hz at 400Hz: G11S) • 1/3000 for 40HP and above</li> <li>Digital setting : 0.01Hz at Maximum frequency of up to 99.99Hz (0.1Hz at Maximum frequency of 100Hz and above)</li> <li>LINK setting : 1/20000 of Maximum frequency ex.) 0.003Hz at 60Hz, 0.006Hz at 120Hz, (0.02Hz at 400Hz: G11S) • 0.01Hz (Fixed)</li> </ul>			
Control	Control method	<ul style="list-style-type: none"> <li>V/f control (Sinusoidal PWM control) • Dynamic torque-vector control (Sinusoidal PWM control) • Vector control with PG (*) (G11S only)</li> </ul>		
	Voltage / freq. (V/f) characteristic	Adjustable at base and maximum frequency, with AVR control : 320 to 480V (460V), 80 to 240V (230V)		
	Torque boost	Selectable by load characteristics: Constant torque load (Auto/manual), Variable torque load (Manual)		
	Operation method	<ul style="list-style-type: none"> <li>KEYPAD operation :  or  key,  key</li> <li>Digital input signal operation : FWD or REV command, Coast-to-stop command, etc.</li> <li>LINK operation : RS-485 (Standard)</li> <li>T-Link (FUJI private link), PROFIBUS-DP, Interbus-S, DeviceNet, Modbus Plus, JPCN1 (Option)</li> </ul>		
	Frequency setting (Frequency command)	<ul style="list-style-type: none"> <li>KEYPAD operation:  or  key</li> <li>External potentiometer (*) : 1 to 5kΩ (1/2W)</li> <li>Analog input : 0 to +10V DC (0 to +5V DC), 4 to 20mA DC (Reversible) 0 to ±10V DC (0 to ±5V DC) ....Reversible operation by polarized signal can be selected. (Inverse) +10 to 0V DC, 20 to 4mA DC.....Inverse mode operation can be selected.</li> <li>UP/DOWN control : Output frequency increases when UP signal is ON, and decreases when DOWN signal is ON.</li> <li>Multistep frequency : Up to 16 different frequencies can be selected by digital input signal.</li> <li>Pulse train input (*) : 0 to 100kp/s</li> <li>Digital signal (parallel) (*) : 16-bit binary</li> <li>LINK operation : RS-485 (Standard)</li> <li>T-Link (FUJI private link), RPOFIBUS-DP, Interbus-S, DeviceNet, Modbus Plus, JPCN1 (Option)</li> <li>Programmed PATTERN operation: Max. 7 stages</li> </ul>		
	Jogging operation	or  key, FWD or REV digital input signal		
	Running status signal	<ul style="list-style-type: none"> <li>Transistor output (4 points) : RUN, FAR, FDT, OL, LU, TL, etc.</li> <li>Relay output (2 points) : • Same as transistor output • Alarm output (for any fault)</li> <li>Analog output (1 point) : Output frequency, Output current, Output torque, etc.</li> <li>Pulse output (1 point) : Output frequency, Output current, Output torque, etc.</li> </ul>		
	Acceleration / Deceleration time	<ul style="list-style-type: none"> <li>0.01 to 3600s : Independently adjustable acceleration and deceleration • 4 different times are selectable.</li> <li>Mode select : Linear, S-curve (weak), S-curve (strong), Non-linear</li> </ul>		
	Active drive	When the acceleration time reaches 60s, the motor output torque is automatically reduced to rated torque. Then the motor operation mode is changed to torque limiting operation. The acceleration time is automatically extended up to 3 times.		
	Frequency limiter	High and Low limiter can be preset.		
	Bias frequency	Bias frequency can be preset.		
	Gain for frequency setting	Gain for frequency setting can be preset. (0.0 to 200.0%) ex.) Analog input 0 to +5V DC with 200% gain results in maximum frequency at 5V DC.		
	Jump frequency control	Jump frequency (3 points) and its common jump hysteresis width (0 to 30Hz) can be preset.		
	Rotating motor pick up (Flying start)	A rotating motor (including inverse rotating mode) can be smoothly picked up without stopping the motor (speed search method).		
	Auto-restart after momentary power failure	Automatic restart is available without stopping motor after a momentary power failure (speed search method). When "Smooth recovery" mode is selected, the motor speed drop is held minimum. (The inverter searches the motor speed, and smoothly returns to setting frequency. Even if the motor circuit is temporarily opened, the inverter operates without a hitch.)		
	Line / Inverter changeover operation	Controls the switching operation between line power and inverter. The inverter has sequence function inside.		
	Slip compensation	<ul style="list-style-type: none"> <li>The inverter output frequency is controlled according to the load torque to keep motor speed constant. When the value is set at "0.00" and "Torque-vector" is set at "active", the compensation value automatically selects the Fuji standard motor.</li> <li>Slip compensation can be preset for the second motor.</li> </ul>		
	Droop operation	The motor speed droops in proportion to output torque (-9.9 to 0.0Hz).....G11S only.		
	Torque limiting	<ul style="list-style-type: none"> <li>When the motor torque reaches a preset limiting level, this function automatically adjusts the output frequency to prevent the inverter from tripping due to an overcurrent.</li> <li>Torque limiting 1 and 2 can be individually set, and are selectable with a digital input signal.</li> </ul>		
	Torque control	Output torque (or load factor) can be controlled with an analog input signal.....G11S only.		
	PID control	<ul style="list-style-type: none"> <li>This function can control flowrate, pressure, etc. (with an analog feedback signal).</li> <li>Reference • KEYPAD operation (  or  key ) : Setting freq. / Max. freq. X 100 (%) • PATTERN operation : Setting freq./Max. freq. X 100 (%)</li> <li>signal <ul style="list-style-type: none"> <li>Voltage input (Terminal 12) : 0 to +10V DC • DI option input (*) : • BCD, setting freq./Max. freq. X 100 (%)</li> <li>Current input (Terminal C1) : 4 to 20mA DC • Binary, full scale/100 (%)</li> <li>Reversible operation with polarity (Terminal 12) : 0 to ±10V DC</li> <li>Reversible operation with polarity (Terminal 12 + V1) : 0 to ±10V DC • Multistep frequency setting : Setting freq./Max. freq. X 100 (%)</li> <li>Inverse mode operation (Terminal 12) : +10 to 0V DC • RS-485 : Setting freq./Max. freq. X 100 (%)</li> <li>Inverse mode operation (Terminal C1) : 20 to 4mA DC</li> </ul> </li> <li>Feedback signal <ul style="list-style-type: none"> <li>Terminal 12 (0 to +10V DC or +10 to 0V DC)</li> <li>Terminal C1 (4 to 20mA DC or 20 to 4mA DC)</li> </ul> </li> </ul>		
	Automatic deceleration	<ul style="list-style-type: none"> <li>Torque limiter 1 (Braking) is set at "F41: 0" (Same as Torque limiter 2 (Braking)).</li> <li>In deceleration : The deceleration time is automatically extended up to 3 times the setting time for triplex operation even if braking resistor not used.</li> <li>In constant speed operation : Based on regenerative energy, the frequency is increased and triplex operation is active.</li> </ul>		
	Second motor's setting	<ul style="list-style-type: none"> <li>This function is used for two motors switching operation.</li> <li>The second motor's V/f characteristics (base and maximum frequency) can be preset.</li> <li>The second motor's circuit parameter can be preset. Torque-vector control can be applied to both motors.</li> </ul>		
	Energy saving operation	This function minimizes inverter and motor losses at light load.		
	Fan stop operation	This function is used for silent operation or extending the fan's lifetime.		
	Universal DI	Transmits to main controller of LINK operation.		
Universal DO	Outputs command signal from main controller of LINK operation.			
Universal AO	Outputs analog signal from main controller of LINK operation.			
Zero speed control (*)	The stopped motor holds its rotor angle.....G11S only.			
Positioning control (*)	The SY option card can be used for positioning control by differential counter method.			
Synchronized operation (*)	This function controls the synchronize operation between 2 axes with PGs.			

Note: (\*) Option \*1) Inverter may automatically reduce carrier frequency, in accordance with ambient temperature or output current for protecting inverter.

Item		Explanation	
Indication	Operation mode (Running)	<p style="text-align: center;">LED monitor</p> <ul style="list-style-type: none"> <li>Output frequency 1 (Before slip compensation) (Hz)</li> <li>Output frequency 2 (After slip compensation) (Hz)</li> <li>Setting frequency (Hz)</li> <li>Output current (A)</li> <li>Output voltage (V)</li> <li>Motor synchronous speed (r/min)</li> <li>Line speed (m/min)</li> <li>Load shaft speed (r/min)</li> <li>Torque calculation value (%)</li> <li>Input power (kW)</li> <li>PID reference value</li> <li>PID reference value (remote)</li> <li>PID feedback value</li> <li>Trip history :Cause of trip by code (Even when main power supply is off, trip history data of the last 4 trips are retained.)</li> </ul>	<p style="text-align: center;">LCD monitor (Japanese, English, German, French, Spanish, Italian)</p> <div style="border: 1px solid black; padding: 5px; text-align: center; margin-bottom: 10px;">Operation monitor &amp; Alarm monitor</div> <p><b>Operation monitor</b></p> <ul style="list-style-type: none"> <li>Displays operation guidance</li> <li>Bargraph: Output frequency (%), Output current (A), Output torque (%)</li> </ul> <p><b>Alarm monitor</b></p> <ul style="list-style-type: none"> <li>The alarm data is displayed when the inverter trips.</li> </ul> <div style="border: 1px solid black; padding: 5px; text-align: center; margin-bottom: 10px;">Function setting &amp; monitor</div> <p><b>Function setting</b></p> <p>Displays function codes and its data or data code, and changes the data value.</p>
	Stopping	Selected setting value or output value	<p><b>Operation condition</b></p> <ul style="list-style-type: none"> <li>Output frequency (Hz)</li> <li>Output current (A)</li> <li>Output voltage (V)</li> <li>Torque calculation value (%)</li> <li>Setting frequency (Hz)</li> <li>Operation condition (FWD / REV, IL, VL / LU, TL)</li> <li>Motor synchronous speed (r/min)</li> <li>Load shaft speed (r/min)</li> <li>Line speed (m/min)</li> <li>PID reference value</li> <li>PID feedback value</li> <li>Driving torque limiter setting value (%)</li> <li>Braking torque limiter setting value (%)</li> </ul> <p><b>Tester function (I/O check)</b></p> <ul style="list-style-type: none"> <li>Digital I/O : <input type="checkbox"/> (ON), <input type="checkbox"/> (OFF)</li> <li>Analog I/O: (V), (mA), (H), (p/s)</li> </ul> <p><b>Maintenance data</b></p> <ul style="list-style-type: none"> <li>Operation time (h)</li> <li>DC link circuit voltage (V)</li> <li>Temperature at inside air (°C)</li> <li>Temperature at heat sink (°C)</li> <li>Maximum current (A)</li> <li>Main circuit capacitor life(%)</li> <li>Control PC board life (h)</li> <li>Cooling fan operation time (h)</li> <li>Communication error times (KEYPAD,RS-485, Option)</li> <li>ROM version (Inverter, KEYPAD, Option)</li> </ul> <p><b>Load factor calculation</b></p> <ul style="list-style-type: none"> <li>Measurement time (s)</li> <li>Maximum current (A)</li> <li>Average current (A)</li> <li>Average braking power (%)</li> </ul> <p><b>Alarm data</b></p> <ul style="list-style-type: none"> <li>Output frequency (Hz)</li> <li>Output current (A)</li> <li>Output voltage (V)</li> <li>Torque calculation value (%)</li> <li>Setting frequency (Hz)</li> <li>Operation condition (FWD / REV, IL, VL / LU, TL)</li> <li>Operation time (h)</li> <li>DC link circuit voltage (V)</li> <li>Temperature at inside air (°C)</li> <li>Hest sink temperature (°C)</li> <li>Communication error times (KEYPAD,RS-485, Option)</li> <li>Digital input terminal condition (Remote, Communication)</li> <li>Transistor output terminal condition</li> <li>Trip history code</li> <li>Multiple alarm exist</li> </ul>
	Trip mode	<p>Displays the cause of trip by codes as follows.</p> <ul style="list-style-type: none"> <li>OC1 (Overcurrent during acceleration)</li> <li>OC2 (Overcurrent during deceleration)</li> <li>OC3 (Overcurrent during running at constant speed)</li> <li>EF (Ground fault)</li> <li>Lin (Input phase loss)</li> <li>FUS (Fuse blown)</li> <li>OU1 (Overvoltage during acceleration)</li> <li>OU2 (Overvoltage during deceleration)</li> <li>OU3 (Overvoltage running at constant speed)</li> <li>LU (Undervoltage)</li> <li>OH1 (Overheating at heat sink)</li> <li>OH2 (External thermal relay tripped)</li> <li>OH3 (Overtemperature at inside air)</li> <li>dBH (Overheating at DB circuit)</li> <li>OL1 (Motor 1 overload)</li> <li>OL2 (Motor 2 overload)</li> <li>OLU (Inverter unit overload)</li> <li>OS (Overspeed)</li> <li>PG (PG error)</li> <li>Er1 (Memory error)</li> <li>Er2 (KEYPAD panel communication error)</li> <li>Er3 (CPU error)</li> <li>Er4 (Option error)</li> <li>Er5 (Option error)</li> <li>Er6 (Operation procedure error)</li> <li>Er7 (Output phase loss error, impedance imbalance)</li> <li>Er7. (Charging circuit alarm, 40HP or larger)</li> <li>Er8 (RS-485 error)</li> </ul>	
	Charge lamp	When the DC link circuit voltage is higher than 50V, the charge lamp is ON.	
Protection	Overload	Protects the inverter by electronic thermal overload function and by detection of inverter temperature.	
	Overvoltage	Detects DC link circuit overvoltage, and stops the inverter. (460V : 800V DC, 230V : 400V DC)	
	Undervoltage	Detects DC link circuit undervoltage, and stops the inverter. (460V : 400V DC, 230V : 200V DC)	
	Input phase loss	Phase loss protection for power line input.	
	Overheating	Protects the inverter by detection of inverter temperature.	
	Short-circuit	Short-circuit protection for inverter output circuit	
	Ground fault	<ul style="list-style-type: none"> <li>Ground fault protection for inverter output circuit (3-phase current detection method) • Zero-phase current detection method (40HP or larger)</li> </ul>	
	Motor overload	<ul style="list-style-type: none"> <li>The inverter trips, and then protects the motor. • Electronic thermal overload protection can be set for standard motor or inverter motor</li> <li>Thermal time constant (0.5 to 75.0 minutes) can be preset for a special motor.</li> <li>The second motor's electronic thermal overload protection can be preset for 2-motor changeover operation.</li> </ul>	
	DB resistor overheating	<ul style="list-style-type: none"> <li>Prevents DB resistor overheating by internal electronic thermal overload relay (10HP or smaller).</li> <li>Prevents DB resistor overheating by external thermal overload relay attached to DB resistor (15HP or larger). (The inverter stops electricity discharge operation to protect the DB resistor.)</li> </ul>	
	Stall prevention	<ul style="list-style-type: none"> <li>Controls the output frequency to prevent <b>OC</b> (overcurrent) trip when the output current exceeds the limit value during acceleration.</li> <li>Lowers the output frequency to hold almost constant torque when the output current exceeds the limit value during operation at constant speed.</li> <li>Controls the output frequency to prevent <b>OU</b> (overvoltage) trip when the DC link circuit voltage exceeds the limit value during deceleration.</li> </ul>	
	Output phase loss	When the inverter executes auto-tuning, detects each phase impedance imbalance.	
	Motor protection by PTC thermistor	When the motor temperature exceeds allowable value, the inverter trips automatically.	
	Auto reset	When the inverter is tripped, it resets automatically and restarts.	
Condition (Installation and operation)	Installation location*	Free from corrosive gases, flammable gases, oil mist, dusts, and direct sunlight. Indoor use only.	* If the inverter has to be used in an atmosphere including the hydrogen sulfide gases, a special model might be available. Contact Fuji Electric FA.
	Altitude	3300ft(1000m) or less. Applicable to 9800ft(3000m) with power derating (-10%/3300ft(1000m))	
	Ambient temperature	-10 to +50 °C(14 to 122°F). For inverters of 30HP or smaller, remove the ventilation covers when operating it at a temperature of 40°C(104°F) or above.	
	Ambient humidity	5 to 95%RH (non-condensing)	
	Vibration	3mm at from 2 to less than 9Hz, 9.8m/s <sup>2</sup> at from 9 to less than 20Hz, 2m/s <sup>2</sup> at from 20 to less than 55Hz (2m/s <sup>2</sup> at from 9 to less than 55Hz :G11S 125HP, P11S 150HP or more) 1m/s <sup>2</sup> at from 55 to less than 200Hz,	
Storage condition	-Temperature : -25 to +65 °C(-13 to 149°F), -Humidity : 5 to 95%RH (non-condensing)		

# Terminal Functions

## Terminal Functions

	Symbol	Terminal name	Function	Remarks
Main circuit	L1/R, L2/S,L3/T	Power input	Connect a 3-phase power supply.	
	U, V, W	Inverter output	Connect a 3-phase induction motor.	
	P1, P(+)	For DC REACTOR	Connect the DC REACTOR for power-factor correcting or harmonic current reducing.	DC REACTOR: 75HP or smaller : Option 100HP or larger : Standard
	P(+), N(-)	For BRAKING UNIT	• Connect the BRAKING UNIT (Option). • Used for DC bus connection system.	BRAKING UNIT (Option): G11S: 15HP or larger, P11S: 20HP or larger.
	P(+), DB	For EXTERNAL BRAKING RESISTOR	Connect the EXTERNAL BRAKING RESISTOR (Option)	G11S : 10HP or smaller, P11S : 15HP or smaller
	⊕ G	Grounding	Ground terminal for inverter chassis (housing).	
RO, T0	Auxiliary control power supply	Connect the same AC power supply as that of the main circuit to back up the control circuit power supply.	1HP or smaller: Not correspond	
Analog input	13	Potentiometer power supply	+10V DC power supply for frequency setting POT ( POT: 1 to 5kΩ )	• Allowable maximum output current : 10mA
	12	Voltage input	• 0 to +10V DC/0 to 100% (0 to +5V DC/0 to 100% ) • Reversible operation can be selected by function setting. 0 to ±10V DC /0 to ±100% (0 to ±5V DC/0 to ±100% ) • Inverse mode operation can be selected by function setting or digital input signal. +10 to 0V DC/0 to 100%	• Input impedance: 22kΩ • Allowable maximum input voltage: ±15V DC • If input voltage is 10 to 15V DC, the inverter estimates it to 10V DC.
		(Torque control) (PID control) (PG feedback)	Used for torque control reference signal. Used for PID control reference signal or feedback signal. Used for reference signal of PG feedback control (option)	
		V2	Voltage input	Frequency is set according to the analog input voltage supplied from an external circuit • 0 to +10V DC/0 to 100% • Reverse operation: +10 to 0V DC/0 to 100% * It can be used only one terminal "V2" or "C1" alternatively * Input resistance: 22kΩ
	C1	Current input	• 4 to 20mA DC/0 to 100% • Inverse mode operation can be selected by function setting or digital input signal. 20 to 4mA DC/0 to 100%	• Input impedance: 250kΩ • Allowable maximum input current: 30mA DC • If input current is 20 to 30mA DC , the inverter estimates it to 20mA DC.
		(PID control)	Used for PID control reference signal or feedback signal.	
11	Common	Common for analog signal	Isolated from terminals CME and CM.	
Digital input	FWD	Forward operation command	FWD - CM: ON ..... The motor runs in the forward direction. FWD - CM: OFF ..... The motor decelerates and stops.	When FWD and REV are simultaneously ON, the motor decelerates and stops.
	REV	Reverse operation command	REV - CM: ON ..... The motor runs in the reverse direction. REV - CM: OFF ..... The motor decelerates and stops.	
	X1	Digital input 1	These terminals can be preset as follows.	• ON state maximum input voltage: 2V (maximum source current : 5mA) • OFF state maximum terminal voltage: 22 to 27V (allowable maximum leakage current: 0.5mA)
	X2	Digital input 2		
	X3	Digital input 3		
	X4	Digital input 4		
	X5	Digital input 5		
	X6	Digital input 6		
	X7	Digital input 7		
	X8	Digital input 8		
	X9	Digital input 9		
	(SS1) (SS2) (SS4) (SS8)	Multistep freq. selection	(SS1) : 2 (0, 1) different frequencies are selectable. (SS1,SS2) : 4 (0 to 3) different frequencies are selectable. (SS1,SS2,SS4) : 8 (0 to 7) different frequencies are selectable. (SS1,SS2,SS4,SS8) : 16 (0 to 15) different frequencies are selectable.	Frequency 0 is set by F01 (or C30). (All signals of SS1 to SS8 are OFF)
	(RT1) (RT2)	ACC / DEC time selection	(RT1) : 2 (0, 1) different ACC / DEC times are selectable. (RT1,RT2) : 4 (0 to 3) different ACC / DEC times are selectable.	Time 0 is set by F07/F08. (All signals of RT1 to RT2 are OFF)
	(HLD)	3-wire operation stop command	Used for 3-wire operation. (HLD) - CM: ON ..... The inverter self-holds FWD or REV signal. (HLD) - CM: OFF ..... The inverter releases self-holding.	Assigned to terminal X7 at factory setting.
	(BX)	Coast-to-stop command	(BX) - CM: ON ..... Motor will coast-to-stop. (No alarm signal will be output.)	• The motor restarts from 0Hz by turning off BX with the operation command (FWD or REV) ON. • Assigned to terminal X8 at factory setting. • During normal operating, this signal is ignored. • Assigned to X9 at factory setting.
	(RST)	Alarm reset	(RST) - CM: ON ..... Faults are reset. (This signal should be held for more than 0.1s.)	This alarm signal is held internally.
	(THR)	Trip command (External fault)	(THR) - CM: OFF ..... "OH2 trip" occurs and motor will coast-to-stop.	This signal is effective only while the inverter is stopping. If this signal is changed while the inverter is running, the signal is effective only after the inverter stops.
	(JOG)	Jogging operation	(JOG) - CM: ON ..... JOG frequency is effective.	If this signal is changed while the inverter is running, the signal is effective only after the inverter stops.
	(Hz2/Hz1)	Freq. set 2 / Freq. set 1	(Hz2/Hz1) - CM: ON ..... Freq. set 2 is effective.	If the operation command(FWD/REV) is input while DC braking is effective, the operation command (FWD/REV) has priority.
	(M2/M1)	Motor 2 / Motor 1	(M2/M1) - CM: ON ..... The motor circuit parameter and V/f characteristics are changed to the second motor's ones.	Main circuit changeover signals are output through Y1 to Y5 terminal.
	(DCBRK)	DC brake command	(DCBRK) - CM: ON ..... The DC injection brake is effective. (In the inverter deceleration mode)	When UP and DOWN commands are simultaneously ON, DOWN signal is effective.
	(TL2/TL1)	Torque limiter 2 / Torque limiter 1	(TL2/TL1) - CM: ON ..... Torque limiter 2 is effective.	• The output frequency change rate is determined by ACC / DEC time. • Restarting frequency can be selected from 0Hz or setting value at the time of stop.
	(SW50) (SW60)	Switching operation between line and inverter	(SW50(SW60)) - CM: ON ..... The motor is changed from inverter operation to line operation. (SW50(SW60)) - CM: OFF ..... The motor is changed from line operation to inverter operation.	When UP and DOWN commands are simultaneously ON, DOWN signal is effective.
	(UP)	UP command	(UP) - CM: ON ..... The output frequency increases.	
	(DOWN)	DOWN command	(DOWN) - CM: ON ..... The output frequency decreases.	
	(WE-KP)	Write enable for KEYPAD	(WE-KP) - CM: ON ..... The data is changed by KEYPAD.	
	(Hz/PID)	PID control cancel	(Hz/PID) - CM: ON ..... The PID control is canceled, and frequency setting by KEYPAD ( [ ] or [ ] ) is effective.	
(IVS)	Inverse mode changeover	(IVS) - CM: ON ..... Inverse mode is effective in analog signal input.	If this signal is changed while the inverter is running, the signal is effective only after the inverter stops.	
(IL)	Interlock signal for 52-2	Connect to auxiliary contact (1NC) of 52-2.		
(Hz/TRQ)	TRQ control cancel	(Hz/TRQ) - CM: ON ..... The torque control is canceled, and ordinary operation is effective.		
(LE)	Link enable (RS-485, Bus)	(LE) - CM: ON ..... The link operation is effective. Used to switch operation between ordinary operation and link operation to communication.	RS-485: Standard, Bus: Option	
(U-DI)	Universal DI	This signal is transmitted to main controller of LINK operation.		
(STM)	Pick up start mode	(STM) - CM: ON ..... The "Pick up" start mode is effective.		
(PG/Hz)	SY-PG enabled	(PG/Hz) - CM: ON ..... Synchronized operation or PG-feedback operation is effective.	Option	
(SYC)	Synchronization command	(SYC) - CM: ON ..... The motor is controlled for synchronized operation between 2 axes with PGs.	Option	
(ZERO)	Zero speed command	(ZERO) - CM: ON ..... The motor decelerates and holds its rotor angle.	This function can be selected at PG feedback control. Option	
(STOP1)	Forced stop command	(STOP1) - CM: ON ..... The motor decelerates and stops.		
(STOP2)	Forced stop command with Deceleration time4	(STOP2) - CM: ON ..... The motor decelerates and stops with Deceleration time4.		
(EXITE)	Pre-exciting command:	(EXITE) - CM: ON ..... The magnetic flux can be established preliminary before starting at PG vector mode.		
PLC	PLC terminal	Connect PLC power supply to avoid malfunction of the inverter that has SINK type digital input, when PLC power supply is off.		
CM	Common	Common for digital signal	Isolated from terminals CME and 11.	

# Terminal Functions

	Symbol	Terminal name	Function	Remarks
Analog output	FMA  (11)	Analog monitor  (Common)	Output voltage (0 to 10V DC) is proportional to selected function's value as follows. The proportional coefficient and bias value can be preset. <ul style="list-style-type: none"> <li>Output frequency 1 (Before slip compensation) (0 to max. frequency)</li> <li>Output frequency 2 (After slip compensation) (0 to max. frequency)</li> <li>Output current (0 to 200%)</li> <li>Output voltage (0 to 200%)</li> <li>Output torque (0 to 200%)</li> <li>Load factor (0 to 200%)</li> <li>Input power (0 to 200%)</li> <li>PID feedback value (0 to 100%)</li> <li>PG feedback value (0 to max. speed)</li> <li>DC link circuit voltage (460V : 0 to 1000V) (230V : 0 to 500V)</li> </ul>	Allowable maximum output current: 2mA
Pulse output	FMP  (CM)	Pulse rate monitor  (Common)	<ul style="list-style-type: none"> <li>Pulse rate mode : Pulse rate is proportional to selected function's value* (50% duty pulse)</li> <li>Average voltage mode : Average voltage is proportional to selected function's value* (2670P/S pulse width control)</li> </ul> <p>* Kinds of function to be output is same as those of analog output (FMA).</p>	Allowable maximum output current : 2mA
Transistor output	Y1	Transistor output 1	Output the selected signals from the following items.	<ul style="list-style-type: none"> <li>ON state maximum output voltage : 2V (Allowable maximum sink current : 50mA)</li> <li>OFF state maximum leakage current : 0.1mA (Allowable maximum voltage : 27V)</li> </ul>
	Y2	Transistor output 2		
	Y3	Transistor output 3		
	Y4	Transistor output 4		
	(RUN)	Inverter running	Outputs ON signal when the output frequency is higher than starting frequency.	
	(FAR)	Frequency equivalence signal	Outputs ON signal when the difference between output frequency and setting frequency is smaller than FAR hysteresis width.	
	(FDT1)	Frequency level detection	Outputs ON signal by comparison of output frequency and preset value (level and hysteresis).	
	(LU)	Undervoltage detection signal	Outputs ON signal when the inverter stops by undervoltage while the operation command is ON.	
	(B/D)	Torque polarity	Outputs ON signal in braking or stopping mode, and OFF signal in driving mode.	
	(TL)	Torque limiting	Outputs ON signal when the inverter is in torque-limiting mode.	
	(IPF)	Auto-restarting	Outputs ON signal during auto restart operation mode.(including "restart time")	
	(OL1)	Overload early warning	<ul style="list-style-type: none"> <li>Outputs ON signal when the electronic thermal value is higher than preset alarm level.</li> <li>Outputs ON signal when the output current value is higher than preset alarm level.</li> </ul>	
	(KP)	KEYPAD operation mode	Outputs ON signal when the inverter is in KEYPAD operation mode.	
	(STP)	Inverter stopping	Outputs ON signal when the inverter is stopping mode or in DC braking mode.	
	(RDY)	Ready output	Outputs ON signal when the inverter is ready for operation.	
	(SW88)	Line/Inv changeover (for 88)	Outputs 88's ON signal for Line/Inverter changeover operation.	
	(SW52-2)	Line/Inv changeover (for 52-2)	Outputs 52-2's ON signal for Line/Inverter changeover operation.	
	(SW52-1)	Line/Inv changeover (for 52-1)	Outputs 52-1's ON signal for Line/Inverter changeover operation.	
	(SWM2)	Motor2/Motor1	Outputs the motor changeover switch ON signal from motor 1 to motor 2.	
	(AX)	Auxiliary terminal (for 52-1)	Used for auxiliary circuit of 52-1. (Same function as AX1, AX2 terminal by FRENIC5000G9S series. (40HP or larger))	Refer to wiring diagram example.
	(TU)	Time-up signal	Outputs time up signal (100ms ON pulse) at every stage end of PATTERN operation.	
	(TO)	Cycle completion signal	Outputs one cycle completion signal (100ms ON pulse) at PATTERN operation.	
	(STG1)	Stage No indication 1	Outputs PATTERN operation's stage No. by signals STG1, STG2 and STG4.	
	(STG2)	Stage No indication 2		
	(STG4)	Stage No indication 4		
	(AL1)	Alarm indication 1	Outputs trip alarm No. by signals AL1, AL2, AL4, and AL8.	
	(AL2)	Alarm indication 2		
	(AL4)	Alarm indication 4		
	(AL8)	Alarm indication 8		
	(FAN)	Fan operation signal	Outputs the inverter cooling fan operation status signal.	
	(TRY)	Auto-resetting	Outputs ON signal at auto resetting mode. (Including "Reset interval")	
	(U-DO)	Universal DO	Outputs command signal from main controller of LINK operation.	
	(OH)	Overheat early warning	Outputs ON signal when the heat sink temperature is higher than (trip level - 10°C(14°F)), and outputs OFF signal when the temperature is lower than (trip level - 15°C(5°F)).	
	(SY)	Synchronization completion signal	Synchronization completion signal for synchronized operation.	Option
(LIFE)	Lifetime alarm	Outputs ON signal when the calculated lifetime is longer than preset alarm level.		
(FDT2)	2nd Freq. level detection	2nd-outputs ON signal by comparison of output frequency and preset value (FDT2 level).		
(OL2)	2nd OL level early warning	2nd-outputs ON signal when the output current value is larger than preset alarm level (OL2 level).		
(C1OFF)	Terminal C1 off signal	Outputs ON signal when the C1 current is smaller than 2mA.		
(DNZS)	Speed existence signal	Outputs ON signal at detection of motor speed when using OPC-G11S-PG/PG2/SY.		
	CME	Common (transistor output)	Common for transistor output signal.	Isolated from terminals CM and 11.
Relay output	30A, 30B, 30C	Alarm relay output	Outputs a contact signal when a protective function is activated.	<ul style="list-style-type: none"> <li>Contact rating : 250V AC, 0.3A, <math>\cos\phi=0.3</math></li> <li>48V DC, 0.5A, non-inductive</li> </ul>
	Y5A, Y5C	Relay output	Changeable exciting mode active or non-exciting mode active by function "F36". Functions can be selected the same as Y1 to Y4. Changeable exciting mode active or non-exciting mode active by function "E25".	
LINK	DXA, DXB, SD	RS-485 I/O terminal	Connect the RS-485 link signal.	

# Basic Wiring Diagram

## Keypad panel Operation

The following diagram is for reference only. For detailed wiring diagrams, refer to the relevant instruction manual.

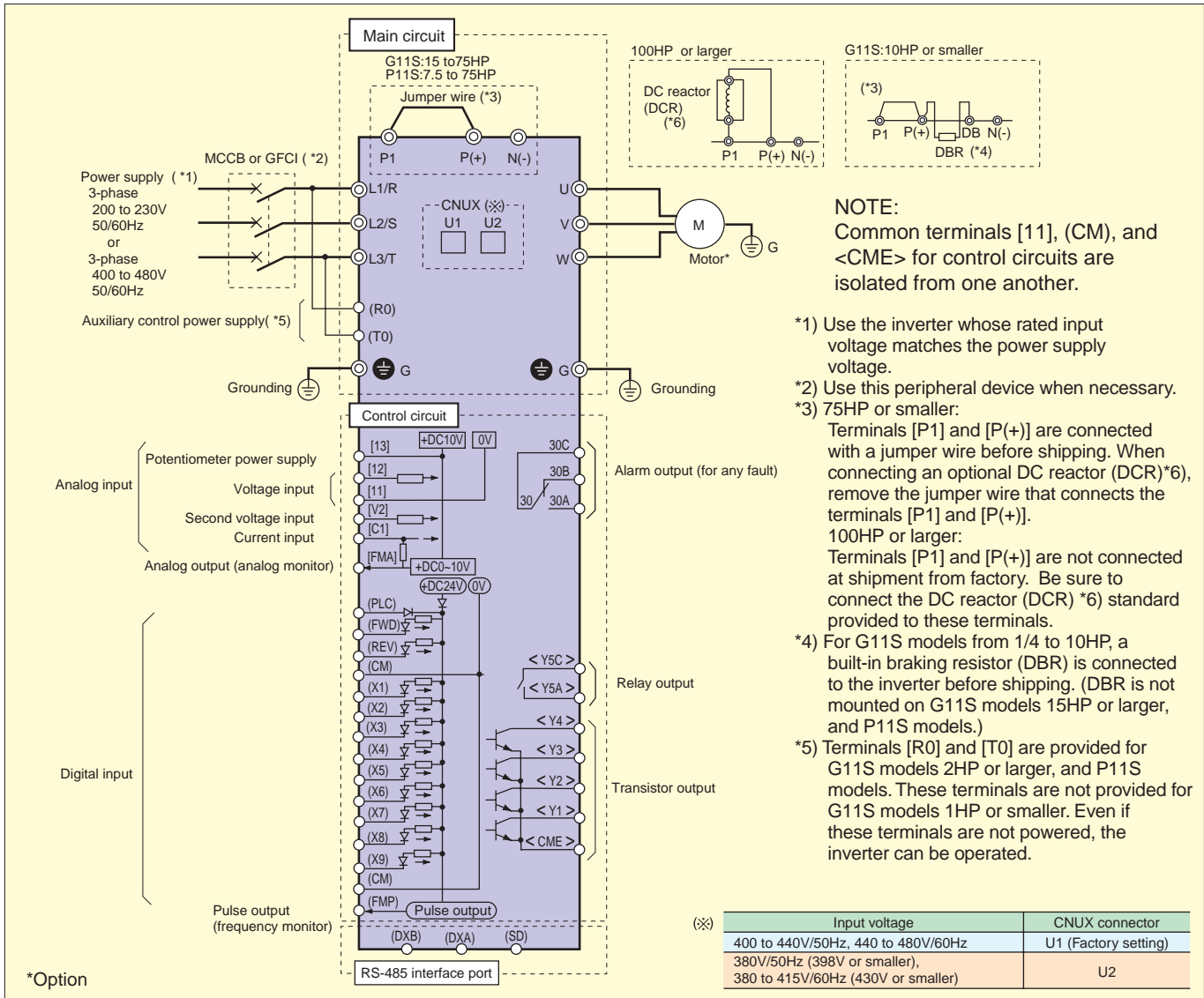

## Terminal Arrangement

### • Main circuit terminals

FRNF25G11S-2UX-FRN001G11S-2UX / FRNF50G11S-4UX-FRN001G11S-4UX



FRN002G11S-2UX-FRN005G11S-2UX / FRN002G11S-4UX-FRN005G11S-4UX

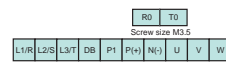

FRN007G11S-2UX-FRN010G11S-2UX / FRN007G11S-4UX-FRN010G11S-4UX  
 FRN007P11S-2UX-FRN015P11S-2UX / FRN007P11S-4UX-FRN015P11S-4UX

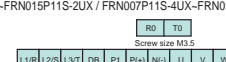

FRN015G11S-2UX-FRN030G11S-2UX / FRN015G11S-4UX-FRN030G11S-4UX  
 FRN020P11S-2UX-FRN030P11S-2UX / FRN020P11S-4UX-FRN030P11S-4UX

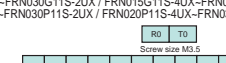

FRN040G11S-2UX / FRN040G11S-4UX-FRN075G11S-4UX  
 FRN040P11S-2UX-FRN050P11S-2UX / FRN040P11S-4UX-FRN100P11S-4UX



FRN500G11S-4UX-FRN600G11S-4UX  
 FRN700P11S-4UX-FRN800P11S-4UX



FRN050G11S-2UX-FRN075G11S-2UX / FRN100G11S-4UX-FRN150G11S-4UX  
 FRN060P11S-2UX-FRN100P11S-2UX / FRN125P11S-4UX-FRN200P11S-4UX

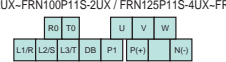

FRN100G11S-2UX  
 FRN125P11S-2UX



FRN125G11S-2UX / FRN200G11S-4UX-FRN350G11S-4UX  
 FRN150P11S-2UX / FRN250P11S-4UX-FRN450P11S-4UX



FRN400G11S-4UX-FRN450G11S-4UX  
 FRN500P11S-4UX-FRN600P11S-4UX



FRN500G11S-4UX-FRN600G11S-4UX  
 FRN700P11S-4UX-FRN800P11S-4UX



### • Control circuit terminals

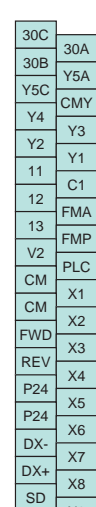

# External signal input Operation

The following diagram is for reference only. For detailed wiring diagrams, refer to the relevant instruction manual.

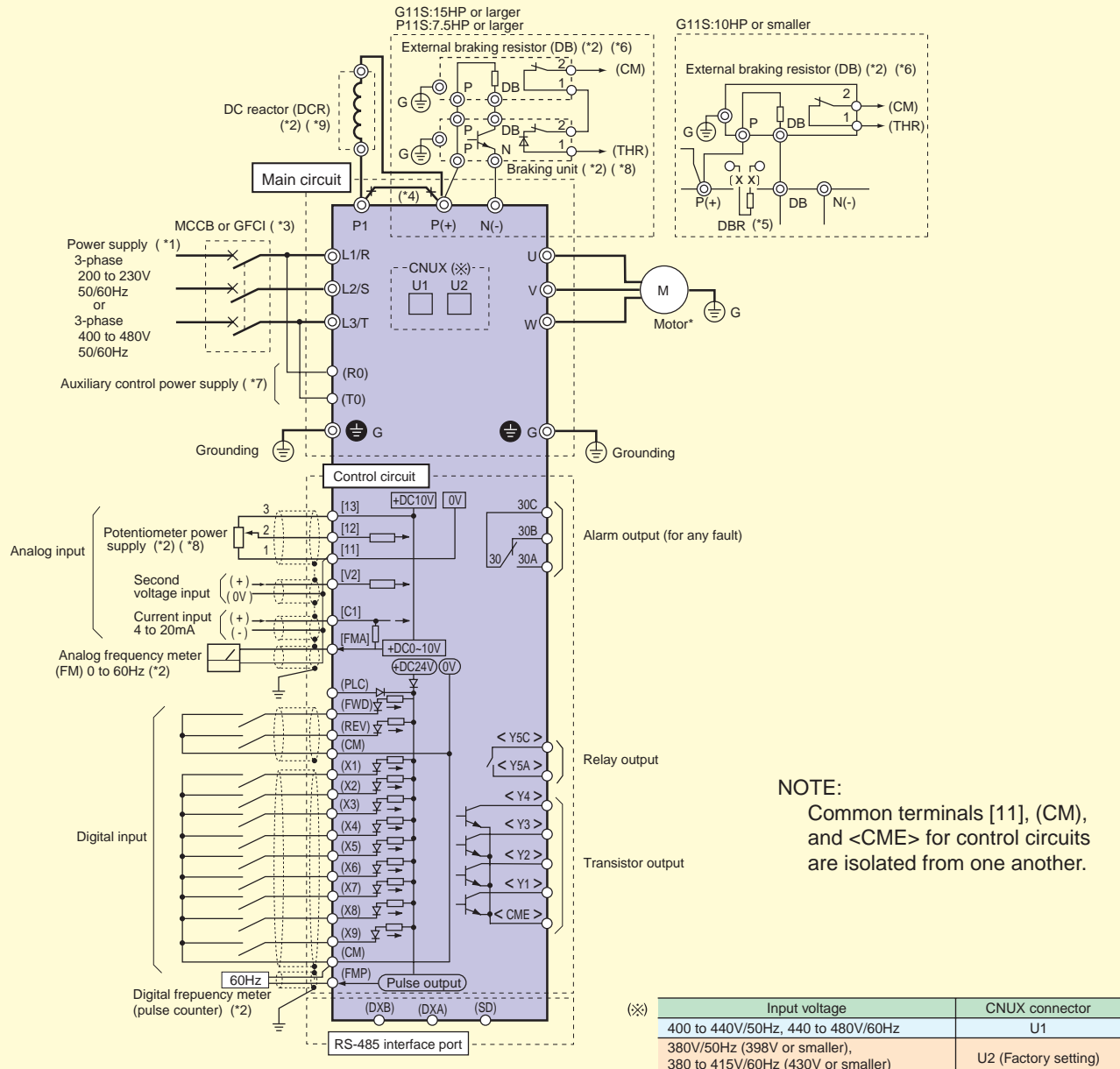

**NOTE:**  
Common terminals [11], (CM), and <CME> for control circuits are isolated from one another.

\*Option

- \*1) Use the inverter whose rated input voltage matches the power supply voltage.
- \*2) An optional device. Use it when necessary.
- \*3) Use this peripheral device when necessary.
- \*4) 15HP or smaller:  
Terminals [P1] and [P(+)] are connected with a jumper wire before shipping. When connecting an optional DC reactor (DCR) \*9), remove the jumper wire that connects the terminals [P1] and [P(+)].  
100HP or larger:  
Terminals [P1] and [P(+)] are not connected at shipment from factory. Be sure to connect the DC reactor (DCR) \*9) standard provided to these terminals.
- \*5) For G11S models from 1/4 to 10HP, a built-in braking resistor (DBR) is connected to the inverter before shipping. (DBR is not

- mounted on G11S models 15HP or larger, and P11S models.)
- When connecting an optional external braking resistor (DB), remove the DBR connection cables from [P(+)] and [DB] terminals. The end of the removed cables (indicated with an X) must be insulated.
- \*6) When connecting an optional external braking resistor (DB), be sure to also use an optional braking unit \*8). Connect the optional braking unit to the [P(+)] and [N(-)] terminals. Auxiliary terminals [1] and [2] have polarity. Be sure to connect cables to these terminals correctly. (See the diagram)
- \*7) Terminals [R0] and [T0] are provided for G11S models 2HP or larger, and P11S models. These terminals are not provided for G11S models 1HP or smaller. Even if these terminals are not powered, the inverter can be operated.

# Keypad Panel Functions and Operations

## Keypad panel

### LED monitor

In operation mode:  
Displays the setting frequency, output current, voltage, motor speed, or line speed.  
In trip mode:  
Displays code indicating the cause of trip.

### Up/Down keys

In operation mode :  
Increases or decreases the frequency or speed.  
In program mode :  
Increases or decreases function code number and data set value.

### Program key

Switches the display to a menu screen or to the initial screen for operation mode or alarm mode.

### Shift key (Column shift)

In program mode :  
Moves the cursor horizontally at data change. Pressing this key with the UP or DOWN key, the screen changes to the next function block.

### Reset key

In program mode :  
Cancels the current input data and shifts the screen.  
In trip mode :  
Releases the trip-stop state.

### LCD monitor

In operation mode :  
Displays various items of information such as operation condition and function data. Operation guidance, which can be scrolled, is displayed at the bottom.  
In program mode :  
Displays functions and data. This LCD monitor has a back light future.

### Unit indication

Displays the unit for the information shown on the LED monitor.

### FWD/REV keys

In operation mode :  
Starts the inverter with forward or reverse operation command.  
Pressing the FWD or REV key lights the RUN lamp. Invalid when the function code F02 (Operation method) is set at 1 (External signal operation).

### Stop key

In operation mode :  
Stops the inverter. Invalid when the function code F02 (Operation method) is set at 1 (External signal operation).





### Function/Data Select key

In operation mode :  
Changes the displayed values of LED monitor.  
In program mode :  
Selects the function code or stores the data.





## Keypad panel operation

Perform the wiring shown in the Basic wiring diagram on page 14. Turn on inverter power, and use the  or  key to set an output frequency. Press the  key, then press the  or  key.

The inverter starts running using the factory setting function data.

Press the  key to stop the inverter.

### Procedure for selecting function codes and data codes

The following is a sample procedure for selecting a function code and changing the function data.

- ① Press the  key to switch the operation monitor screen to the program menu screen.







```

RUN                                FWD
PRG → PRG  MENU
F/D → LED  SHIFT
  
```

- ② Select "1. DATA SET", and press the  key.





```

→ 1. DATA SET
   2. DATA CHECK
   3. OPR MNTR
   4. I / O CHECK
  
```

- ③ Press the  or  key to select a target function code. To quickly scroll the function select screen, press  key and the  or  key at the same time. At the target function, press  key.

```

F00 DATA PRTC
F01 FREQ CMD 1
F02 OPR METHOD
F03 MAX Hz-1
  
```

- ④ Use the , , and  keys to change the function data to the target value. (Use the  key to move the cursor when you want to enter a numerical value.)

```

F01  FREQ CMD 1
           0
0~11
  
```

- ⑤ Press the  key to store the updated function data in memory. The screen shifts for the selection of the next function.

```



F02 OPR METHOD
F03 MAX Hz-1
F04 BASE Hz-1
F05 RATED V-1
  
```

- ⑥ Pressing the  key switches the screen to the operation monitor screen.

```

RUN                                FWD
PRG → PRG  MENU
F/D → LED  SHIFT
  
```

#### 1) Setting a frequency





When the operation monitor screen is displayed, a frequency can be set by using the  or  key in both the operation and stop modes. When the target frequency is displayed, press the  key to enter the frequency in memory.

#### 2) Switching a unit indication

During both operation and stop modes, each time the  key is pressed, the value displayed on the LED monitor changes, and the unit indication on the LCD monitor shifts from Hz to A, V, r/min, m/min, kW, and % in this order in accordance with the displayed value.

# Function settings

## Fundamental Functions

Basic Functions	Function		Setting range	Min. unit	Factory setting	
	Code	Name			LCD monitor	-30HP
	F00	Data protection	F00 DATA PRTC	0 : Data change enable 1 : Data protection	-	0
	F01	Frequency command 1	F01 FREQ CMD 1	0 : KEYPAD operation (  or  key) 1 : Voltage input (terminals 12) (0 to +10V DC, 0 to +5V DC) 2 : Current input (terminal C1) (4 to 20mA DC) 3 : Voltage and current input (terminals 12 and C1) 4 : Reversible operation with polarity (terminal 12)(0 to ±10V DC) 5 : Reversible operation with polarity (terminals 12 and V1) (0 to ±10V DC) 6 : Inverse mode operation (terminals 12) (+10 to 0V DC) 7 : Inverse mode operation (terminal C1) (20 to 4mA DC) 8 : UP/DOWN control 1 (initial freq. = 0Hz) 9 : UP/DOWN control 2 (initial freq. = last value) 10 : PATTERN operation 11 : DI option or Pulse train input	-	0
	F02	Operation method	F02 OPR METHOD	0 : KEYPAD operation (  or  key) 1 : FWD or REV command signal operation	-	0
	F03	Maximum frequency 1	F03 MAX Hz-1	G11S : 50 to 400Hz P11S : 50 to 120Hz	1Hz	60
	F04	Base frequency 1	F04 BASE Hz-1	G11S : 25 to 400Hz P11S : 25 to 120Hz	1Hz	60
	F05	Rated voltage 1 (at Base frequency 1)	F05 RATED V-1	0(Free), 320 to 480V (460V class) 0(Free), 80 to 240V (230V class)	1V	460 230
	F06	Maximum voltage 1 (at Maximum frequency 1)	F06 MAX V-1	320 to 480V (460V class) 80 to 240V (230V class)	1V	460 230
	F07	Acceleration time 1	F07 ACC TIME1	0.01 to 3600s	0.01s	6.00   20.00
	F08	Deceleration time 1	F08 DEC TIME1	0.01 to 3600s	0.01s	6.00   20.00
	F09	Torque boost 1	F09 TRQ BOOST1	0.0 : Automatic (for constant torque load) 0.1 to 1.9 : Manual (for variable torque load) 2.0 to 20.0 : Manual (for constant torque load)	0.1	G11S : 2.0 P11S : 2.0
	F10	Electronic thermal overload protection for motor 1 (Select)	F10 ELCTRN OL1	0 : Inactive 1 : Active (for 4-pole standard motor) 2 : Active (for 4-pole inverter motor)	-	1
	F11	(Level)	F11 OL LEVEL1	Approx. 20 to 135% of rated current	0.01A	*1)
	F12	(Thermal time constant)	F12 TIME CNST 1	0.5 to 75.0 min	0.1min	5.0   10.0
	F13	Electronic thermal overload protection (for braking resistor)	F13 DBR OL	G11S [10HP or smaller] 0 : Inactive 1 : Active (built-in braking resistor) 2 : Active (DB***-2C / 4C external braking resistor) [15HP or larger] 0 : Inactive P11S [15HP or smaller] 0,1 : Inactive 2 : Active (DB***-2C / 4C external braking resistor) [20HP or larger] 0 : Inactive	-	1 0 0
	F14	Restart mode after momentary power failure (operation selection)	F14 RESTART	0 : Inactive (Trip and alarm when power failure occurs.) 1 : Inactive (Trip, and alarm when power recovers.) 2 : Inactive (Deceleration stop, and alarm.) 3 : Active (Smooth recovery by continuous operation mode) 4 : Active (Momentarily stops and restarts at output frequency of before power failure) 5 : Active (Momentarily stops and restarts at starting frequency)	-	1
	F15	Frequency limiter (High)	F15 H LIMITER	G11S : 0 to 400Hz P11S : 0 to 120Hz	1Hz	70
	F16	Frequency limiter (Low)	F16 L LIMITER	G11S : 0 to 400Hz P11S : 0 to 120Hz	1Hz	0
	F17	Gain (for frequency setting signal)	F17 FREQ GAIN	0.0 to 200.0%	0.1%	100.0
	F18	Bias frequency	F18 FREQ BIAS	G11S : -400.0 to 400.0Hz P11S : -120.0 to 120.0Hz	0.1Hz	0.0
	F20	DC brake (Starting freq.)	F20 DC BRK Hz	0.0 to 60.0Hz	0.1Hz	0.0
	F21	DC brake (Braking level)	F21 DC BRK LVL	G11S : 0 to 100%	1%	0
	F22	DC brake (Braking time)	F22 DC BRK t	0.0 (DC brake inactive), 0.1 to 30.0s	0.1s	0.0
	F23	Starting frequency (Freq.)	F23 START Hz	0.1 to 60.0Hz	0.1Hz	0.5
	F24	(Holding time)	F24 HOLDING t	0.0 to 10.0s	0.1s	0.0
	F25	Stop frequency	F25 STOP Hz	0.1 to 60.0Hz	0.1Hz	0.2
	F26	Motor sound (Carrier freq.)	F26 MTR SOUND	0.75 to 15kHz (G11S : 75HP or smaller, P11S : 30HP or smaller) 0.75 to 10kHz (G11S : 100 to 600HP, P11S : 40 to 100HP) 0.75 to 6kHz (P11S : 125 to 800HP)	1kHz	2
	F27	(Sound tone)	F27 MTR TONE	0 : level 0 1 : level 1 2 : level 2 3 : level 3	-	0
	F30	FMA (Voltage adjust)	F30 FMA V-ADJ	0 to 200%	1%	100
	F31	(Function)	F31 FMA FUNC	0 : Output frequency 1 (Before slip compensation) 1 : Output frequency 2 (After slip compensation) 2 : Output current 3 : Output voltage 4 : Output torque 5 : Load factor 6 : Input power 7 : PID feedback value 8 : PG feedback value 9 : DC link circuit voltage 10 : Universal AO	-	0
	F33	FMP (Pulse rate)	F33 FMP PULSES	300 to 6000 p/s (at full scale)	1p/s	1440
	F34	(Voltage adjust)	F34 FMP V-ADJ	0% : (Pulse rate output: 50% duty) 1 to 200% : (Voltage adjust: 2670p/s, duty adjust)	1%	0
	F35	(Function)	F35 FMP FUNC	0 : Output frequency 1 (Before slip compensation) 1 : Output frequency 2 (After slip compensation) 2 : Output current 3 : Output voltage 4 : Output torque 5 : Load factor 6 : Input power 7 : PID feedback value 8 : PG feedback value 9 : DC link circuit voltage 10 : Universal AO	-	0
	F36	30RY operation mode	F36 30RY MODE	0 : The relay (30) excites on trip mode. 1 : The relay (30) excites on normal mode.	-	0
	F40	Torque limit 1 (Driving)	F40 DRV TRQ 1	G11S : 20 to 200, 999% (999: No limit) *2) P11S : 20 to 150, 999% (999: No limit)	1%	999
	F41	(Braking)	F41 BRK TRQ 1	G11S : 0 (Automatic deceleration control), 20 to 200, 999% (999: No limit) *2) P11S : 0 (Automatic deceleration control), 20 to 150, 999% (999: No limit)	1%	999
	F42	Torque vector control 1	F42 TRQVECTOR1	0 : Inactive 1 : Active	-	0

The functions in the yellow boxes can be set while the inverter is running. Other functions must be set while the inverter is stopped.

# Extension Terminal Functions

	Function			Setting range	Min. unit	Factory setting				
	Code	Name	LCD monitor			-30HP	40HP-			
X1-X9 Terminal	E01	X1 terminal function	E01 X1 FUNC	Selects from the following items.  0 : Multistep freq. selection (1 to 4 bit) 1 : 2 : 3 : 4 : 5 : ACC / DEC time selection (1 to 2 bit) 6 : 3-wire operation stop command 7 : Coast-to-stop command 8 : Alarm reset 9 : Trip command (External fault) 10 : Jogging operation 11 : Freq. set. 2 / Freq. set. 1 12 : Motor 2 / Motor 1 13 : DC brake command 14 : Torque limiter 2 / Torque limiter 1 15 : Switching operation between line and inverter (50Hz) 16 : Switching operation between line and inverter (60Hz) 17 : UP command 18 : DOWN command 19 : Write enable for KEYPAD 20 : PID control cancel 21 : Inverse mode changeover (terminals 12 and C1) 22 : Interlock signal for 52-2 23 : TRQ control cancel 24 : Link enable (Bus,RS-485) 25 : Universal DI 26 : Pick up start mode 27 : SY-PG enable 28 : Synchronization command 29 : Zero speed command 30 : Forced stop command 31 : Forced stop command with Deceleration time 4 32 : Pre-exciting command 33 : Line speed control Cancellation 34 : Line speed frequency memory 35 : Frequency setting 1 / Frequency setting 2	-	0				
	E02	X2 terminal function	E02 X2 FUNC		-	1				
	E03	X3 terminal function	E03 X3 FUNC		-	2				
	E04	X4 terminal function	E04 X4 FUNC		-	3				
	E05	X5 terminal function	E05 X5 FUNC		-	4				
	E06	X6 terminal function	E06 X6 FUNC		-	5				
	E07	X7 terminal function	E07 X7 FUNC		-	6				
	E08	X8 terminal function	E08 X8 FUNC		-	7				
	E09	X9 terminal function	E09 X9 FUNC		-	8				
	ACC 2,3,4 DEC 2,3,4	E10	Acceleration time 2		E10 ACC TIME2	0.01 to 3600s	0.01s	6.00	20.00	
		E11	Deceleration time 2		E11 DEC TIME2		0.01s	6.00	20.00	
		E12	Acceleration time 3		E12 ACC TIME3		0.01s	6.00	20.00	
		E13	Deceleration time 3		E13 DEC TIME3		0.01s	6.00	20.00	
		E14	Acceleration time 4		E14 ACC TIME4		0.01s	6.00	20.00	
		E15	Deceleration time 4		E15 DEC TIME4		0.01s	6.00	20.00	
		E16	Torque limit 2 (Driving)		E16 DRV TRQ 2	G11S : 20 to 200%, 999% (999: No limit) *2) P11S : 20 to 150%, 999% (999: No limit) G11S : 0 (Automatic deceleration control), 20 to 200%, 999% (999: No limit) *2) P11S : 0 (Automatic deceleration control), 20 to 150%, 999% (999: No limit)	1%	999		
		E17	(Braking)		E17 BRK TRQ 2		1%	999		
	Y1-Y5C Terminal	E20	Y1 terminal function		E20 Y1 FUNC	Selects from the following items.  0 : Inverter running [RUN] 1 : Frequency equivalence signal [FAR] 2 : Frequency level detection [FDT1] 3 : Undervoltage detection signal [LU] 4 : Torque polarity [B/D] 5 : Torque limiting [TL] 6 : Auto-restarting [IPF] 7 : Overload early warning [OL1] 8 : KEYPAD operation mode [KP] 9 : Inverter stopping [STP] 10 : Ready output [RDY] 11 : Line/Inv changeover ( for 88) [SW88] 12 : Line/Inv changeover ( for 52-2) [SW52-2] 13 : Line/Inv changeover ( for 52-1) [SW52-1] 14 : Motor 2 / Motor 1 [SWM2] 15 : Auxiliary terminal (for 52-1) [AX] 16 : Time-up signal [TU] 17 : Cycle completion signal [TO] 18 : Stage No. indication 1 [STG1] 19 : Stage No. indication 2 [STG2] 20 : Stage No. indication 4 [STG4] 21 : Alarm indication 1 [AL1] 22 : Alarm indication 2 [AL2] 23 : Alarm indication 4 [AL4] 24 : Alarm indication 8 [AL8] 25 : Fan operation signal [FAN] 26 : Auto-resetting [TRY] 27 : Universal DO [U-DO] 28 : Overheat early warning [OH] 29 : Synchronization completion signal [SY] 30 : Life expectancy detection signal [LIFE] 31 : 2nd Freq. level detection [FDT2] 32 : 2nd OL level early warning [OL2] 33 : Terminal C1 off signal [C1OFF] 34 : Speed existance signal [DNZS] 35 : Speed agreement signal [DSAG] 36 : PG error signal [PG-ABN] 37 : Torque limiting (Signal with delay) [TL2]	-	0		
		E21	Y2 terminal function		E21 Y2 FUNC		-	1		
		E22	Y3 terminal function		E22 Y3 FUNC		-	2		
		E23	Y4 terminal function		E23 Y4 FUNC		-	7		
		E24	Y5A, Y5C terminal function		E24 Y5 FUNC		-	10		
			E25		Y5 RY operation mode		E25 Y5RY MODE	0 : Inactive (Y5 Ry excites at "ON signal" mode.) 1 : Active (Y5 Ry excites at "OFF signal" mode.)		
			E30		FAR function signal (Hysteresis)		E30 FAR HYSTR		0.0 to 10.0 Hz	0.1Hz
			E31		FDT1 function signal (Level)		E31 FDT1 LEVEL	G11S : 0 to 400 Hz P11S : 0 to 120 Hz	1Hz	60
			E32		(Hysteresis)		E32 FDT HYSTR		0.0 to 30.0 Hz	0.1Hz
			E33		OL1 function signal (Mode select)		E33 OL1 WARNING	0 : Thermal calculation 1 : Output current	-	0
			E34		(Level)		E34 OL1 LEVEL		G11S : Approx. 5 to 200% of rated current P11S : Approx. 5 to 150% of rated current	0.01A
			E35		(Timer)		E35 OL TIMER	0.1 to 60.0s	0.1s	10.0
			E36		FDT2 function (Level)		E36 FDT2 LEVEL	G11S : 0 to 400 Hz P11S : 0 to 120 Hz	1Hz	60
			E37		OL2 function (Level)		E37 OL2 LEVEL	G11S : Approx. 5 to 200% of rated current P11S : Approx. 5 to 150% of rated current	0.01A	*1

The functions in the yellow boxes can be set while the inverter is running. Other functions must be set while the inverter is stopped.

# Function settings

## Extension Terminal Functions (cont'd)

	Function		LCD monitor	Setting range	Min. unit	Factory setting	
	Code	Name				-30HP	40HP-
LED & LCD Monitor	E40	Display coefficient A	E40 COEF A	-999.00 to 999.00	0.01		0.01
	E41	Display coefficient B	E41 COEF B	-999.00 to 999.00	0.01		0.00
	E42	LED Display filter	E42 DISPLAY FL	0.0 to 5.0s	0.1s		0.5
	E43	LED Monitor (Function)	E43 LED MNTR	0 : Output frequency 1 (Before slip compensation) (Hz) 1 : Output frequency 2 (After slip compensation) (Hz) 2 : Setting frequency (Hz) 3 : Output current (A) 4 : Output voltage (V) 5 : Motor synchronous speed (r/min) 6 : Line speed (m/min) 7 : Load shaft speed (r/min) 8 : Torque calculation value (%) 9 : Input power 10 : PID reference value 11 : PID reference value (remote) 12 : PID feedback value	-		0
	E44	(Display at STOP mode)	E44 LED MNTR2	0 : Setting value 1 : Output value	-		0
	E45	LCD Monitor (Function)	E45 LCD MNTR	0 : Displays operation guidance 1 : Bar graph (Output freq., Output current, and Output torque)	-		0
	E46	Language	E46 LANGUAGE	0 : Japanese 1 : English 2 : German 3 : French 4 : Spanish 5 : Italian	-		1
	E47	LCD Monitor (Contrast)	E47 CONTRAST	0(Soft) to 10(Hard)	-		5

The functions in the yellow boxes can be set while the inverter is running. Other functions must be set while the inverter is stopped.

## Control Functions of Frequency

	Function		LCD monitor	Setting range	Min. unit	Factory setting	
	Code	Name				-30HP	40HP-
Jump Hz Control	E01	Jump (Jump freq. 1)	C01 JUMP Hz 1	G11S : 0 to 400Hz	P11S : 0 to 120Hz	1Hz	0
	E02	frequency (Jump freq. 2)	C02 JUMP Hz 2			1Hz	0
	E03	(Jump freq. 3)	C03 JUMP Hz 3			1Hz	0
	E04	(Hysteresis)	C04 JUMP HYSTR	0 to 30Hz		1Hz	3
Multi-Hz Control	E05	Multistep (Freq. 1)	C05 MULTI Hz-1	G11S : 0.00 to 400.00Hz	P11S : 0.00 to 120.00Hz	0.01Hz	0.00
	E06	frequency (Freq. 2)	C06 MULTI Hz-2			0.01Hz	0.00
	E07	setting (Freq. 3)	C07 MULTI Hz-3			0.01Hz	0.00
	E08	(Freq. 4)	C08 MULTI Hz-4			0.01Hz	0.00
	E09	(Freq. 5)	C09 MULTI Hz-5			0.01Hz	0.00
	E10	(Freq. 6)	C10 MULTI Hz-6			0.01Hz	0.00
	E11	(Freq. 7)	C11 MULTI Hz-7			0.01Hz	0.00
	E12	(Freq. 8)	C12 MULTI Hz-8			0.01Hz	0.00
	E13	(Freq. 9)	C13 MULTI Hz-9			0.01Hz	0.00
	E14	(Freq. 10)	C14 MULTI Hz10			0.01Hz	0.00
	E15	(Freq. 11)	C15 MULTI Hz11			0.01Hz	0.00
	E16	(Freq. 12)	C16 MULTI Hz12			0.01Hz	0.00
	E17	(Freq. 13)	C17 MULTI Hz13			0.01Hz	0.00
	E18	(Freq. 14)	C18 MULTI Hz14			0.01Hz	0.00
	E19	(Freq. 15)	C19 MULTI Hz15			0.01Hz	0.00
PATTERN Operation	E20	JOG frequency	C20 JOG Hz	G11S : 0.00 to 400.00Hz	P11S : 0.00 to 120.00Hz	0.01Hz	5.00
	E21	PATTERN (Mode select) operation	C21 PATTERN	0 : Active (Mono-cycle operation, and then stops.) 1 : Active (Continuous cyclic operation while operation command is effective.) 2 : Active (Mono-cycle operation, and after continues at the latest setting frequency.)		-	0
	E22	(Stage 1)	C22 STAGE 1	• Operation time: 0.00 to 6000s • F1 to F4 and R1 to R4		0.01s	0.00 F1
	E23	(Stage 2)	C23 STAGE 2			0.01s	0.00 F1
	E24	(Stage 3)	C24 STAGE 3			0.01s	0.00 F1
	E25	(Stage 4)	C25 STAGE 4			0.01s	0.00 F1
	E26	(Stage 5)	C26 STAGE 5			0.01s	0.00 F1
	E27	(Stage 6)	C27 STAGE 6			0.01s	0.00 F1
E28	(Stage 7)	C28 STAGE 7			0.01s	0.00 F1	
	E30	Frequency command 2	C30 FREQ CMD 2	0 : KEYPAD operation ( <input type="checkbox"/> or <input type="checkbox"/> key) 1 : Voltage input (terminal 12) (0 to +10V DC, 0 to +5V DC) 2 : Current input (terminal C1) (4 to 20mA DC) 3 : Voltage and current input (terminals 12 and C1) 4 : Reversible operation with polarity (terminal 12) (0 to ±10V DC) 5 : Reversible operation with polarity (terminal 12 and V1) (0 to ±10V DC) 6 : Inverse mode operation (terminal 12) (+10 to 0V DC) 7 : Inverse mode operation (terminal C1) (20 to 4mA DC) 8 : UP/DOWN control 1 (initial freq. = 0Hz) 9 : UP/DOWN control 2 (initial freq. = last value) 10 : PATTERN operation 11 : DI option or Pulse train input		-	2
	E33	Analog setting signal filter	C33 REF FILTER	0.00 to 5.00s		0.01s	0.05

# Motor Parameters

	Function		LCD monitor	Setting range	Min. unit	Factory setting	
	Code	Name				-30HP	40HP-
Motor 1	P01	Number of motor 1 poles	M1 POLES	2 to 14	2		4
	P02	Motor 1 (Capacity)	M1-CAP	30HP or smaller : 0.01 to 45.00kW 40HP or larger : 0.01 to 800.00kW	0.01kW		*1)
	P03	(Rated current)	M1-Ir	0.00 to 2000 A	0.01A		*1)
	P04	(Tuning)	M1 TUN1	0 : Inactive 1 : Active (One time tuning of %R1 and %X ( on motor stopping mode )) 2 : Active (One time tuning of %R1, %X and lo ( on motor running mode ))	-		0
	P05	(On-line Tuning)	M1 TUN2	0 : Inactive 1 : Active (Real time tuning of %R2)	-		0
	P06	(No-load current)	M1-lo	0.00 to 2000 A	0.01A		*1)
	P07	(%R1 setting)	M1-%R1	0.00 to 50.00 %	0.01%		*1)
	P08	(%X setting)	M1-%X	0.00 to 50.00 %	0.01%		*1)
	P09	(Slip compensation control 1)	SLIP COMP1	0.00 to +15.00	0.01Hz		0.00

The functions in the yellow boxes can be set while the inverter is running. Other functions must be set while the inverter is stopped.

# High Performance Functions

	Function		LCD monitor	Setting range	Min. unit	Factory setting		
	Code	Name				-30HP	40HP-	
High Performance Functions	H03	Data initializing (Data reset)	DATA INIT	0 : Manual set value 1 : Return to factory set value	-		0	
	H04	Auto-reset (Times)	AUTO-RESET	0 (Inactive), 1 to 10 times	1		0	
	H05	(Reset interval)	RESET INT	2 to 20s	1s		5	
	H06	Fan stop operation	FAN STOP	0 : Inactive 1 : Active (Fan stops at low temperature mode)	-		0	
	H07	ACC/DEC pattern (Mode select)	ACC PTN	0 : Inactive (linear acceleration and deceleration) 1 : S-shape acceleration and deceleration (mild) 2 : S-shape acceleration and deceleration (variable) 3 : Curvilinear acceleration and deceleration	-		0	
	H08	Rev. phase sequence lock	REV LOCK	0 : Inactive 1 : Active	-		0	
	H09	Start mode (Rotating motor pick up)	START MODE	0 : Inactive 1 : Active (Only Auto-restart after momentary power failure mode ) 2 : Active (All start modes)	-		0	
	H10	Energy-saving operation	ENERGY SAV	0 : Inactive 1 : Active (Only when torque boost "F09" is set at manual setting mode.)	-		G11S : 0 P11S : 1	
	H11	DEC mode	DEC MODE	0 : Normal (according to "H07" mode) 1 : Coast-to-stop	-		0	
	H12	Instantaneous overcurrent limiting	INST CL	0 : Inactive 1 : Active	-		1	
	H13	Auto-restart (Restart time)	RESTART t	0.1 to 10.0s	0.1s		0.5	
	H14	(Freq. fall rate)	FALL RATE	0.00 to 100.00Hz/s	0.01Hz/s		10.00	
	H15	(Holding DC voltage)	HOLD V	400 to 600V (460V) 200 to 300V (230V)	1V		470V 235V	
	H16	(OPR command selfhold time)	SELFHOLD t	0.0 to 30.0s, 999s (999s : The operation command is held while DC link circuit voltage is larger than 50V.)	0.1s		999	
	H18	Torque control	TRQ CTRL	G11S 0 : Inactive (Frequency control) 1 : Active (Torque control by terminal 12 (Driving)) (0 to +10V/0 to 200%) 2 : Active (Torque control by terminal 12 (Driving & Braking)) (0 to ±10V/0 to ±200%) P11S 0 : Inactive (Fixed)	-		0	
	H19	Active drive	AUT RED	0 : Inactive 1 : Active	-		0	
	PID Control	H20	PID control (Mode select)	PID MODE	0 : Inactive 1 : Active (PID output 0 to 100% / Frefuency 0 to max.) 2 : Active (Inverse operation mode : PID output 0 to 100% / Frefuency max. to 0)	-		0
		H21	(Feedback signal)	FB SIGNAL	0 : Terminal 12 (0 to +10V) 1 : Terminal C1 (4 to 20mA) 2 : Terminal 12 (+10 to 0V) 3 : Terminal C1 (20 to 4mA)	-		1
		H22	(P-gain)	P-GAIN	0.01 to 10.00	0.01		0.10
H23		(I-gain)	I-GAIN	0.0 : Inactive 0.1 to 3600.0s	0.1s		0.0	
H24		(D-gain)	D-GAIN	0.00 : Inactive 0.01 to 10.0s	0.01s		0.00	
H25	(Feedback filter)	FB FILTER	0.0 to 60.0s	0.1s		0.5		
Y1-Y5C Terminal	H26	PTC thermistor (Mode select)	PTC MODE	0 : Inactive 1 : Active	-		0	
	H27	(level)	PTC LEVEL	0.00 to 5.00V	0.01V		1.60	
	H28	Droop operation	DROOP	G11S : -9.9 to 0.0Hz P11S : 0.0 (Fixed)	0.1Hz		0.0	
Serial Link	H30	Serial link (Function select)	LINK FUNC	(Code) (Monitor) (Frequency command) (Operation command) 0 : X - - - x : Valid 1 : X X - - - : Invalid 2 : X - X - - 3 : X X X - -	-		0	
	H31	RS-485 (Address)	485ADDRESS	1 to 31	1		1	
	H32	(Mode select on no response error)	MODE ON ER	0 : Trip and alarm (Er8) 1 : Operation for H33 timer, and alarm (Er8) 2 : Operation for H33 timer, and retry to communicate. * If the retry fails, then the inverter trips("Er 8"). 3 : Continuous operation	-		0	
	H33	(Timer)	TIMER	0 to 60.0s	0.1s		2.0	
	H34	(Baud rate)	BAUD RATE	0 : 19200 bit/s 1 : 9600 2 : 4800 3 : 2400 4 : 1200	-		1	
	H35	(Data length)	LENGTH	0 : 8 bit 1 : 7 bit	-		0	
	H36	(Parity check)	PARITY	0 : No checking 1 : Even parity 2 : Odd parity	-		0	
	H37	(Stop bits)	STOP BITS	0 : 2 bit 1 : 1 bit	-		0	
	H38	(No response error detection time)	NO RES t	0 (No detection), 1 to 60s	1s		0	
	H39	(Response interval)	INTERVAL	0.00 to 1.00s	0.01s		0.01	

# Function Settings

## Alternative Motor Parameters

Function Code	Name	LCD monitor	Setting range	Min. unit	Factory setting	
					-30HP	40HP-
<b>R01</b>	Maximum frequency 2	A01 MAX Hz-2	G11S : 50 to 400Hz P11S : 50 to 120Hz	1Hz	60	
<b>R02</b>	Base frequency 2	A02 BASE Hz-2	G11S : 25 to 400Hz P11S : 25 to 120Hz	1Hz	60	
<b>R03</b>	Rated voltage 2 (at Base frequency 2)	A03 RATED V-2	0 (Free), 320 to 480V (460V) 0 (Free), 80 to 240V (230V)	1V	380 220	
<b>R04</b>	Maximum voltage 2 (at Maximum frequency 2)	A04 MAX V-2	320 to 480V (460V) 80 to 240V (230V)	1V	380 220	
<b>R05</b>	Torque boost 2	A05 TRQ BOOST2	0.0 : Automatic (for constant torque load) 0.1 to 1.9 : Manual (for variable torque load) 2.0 to 20.0 : Manual (for constant torque load)	-	G11S : 2.0 P11S : 2.0	
<b>R06</b>	Electronic thermal overload protection (Select)	A06 ELCTRN OL2	0 : Inactive 1 : Active (for 4-pole standard motor) 2 : Active (for 4-pole inverter motor)	-	1	
<b>R07</b>	for motor 2 (Level)	A07 OL LEVEL2	Approx. 20 to 135% of rated current	0.01A	*1)	
<b>R08</b>	(Thermal time constant)	A08 TIME CNST2	0.5 to 75.0 min	0.1min	5.0	10.0
<b>R09</b>	Torque vector control 2	A09 TRQVECTOR2	0 : Inactive 1 : Active	-	0	
<b>R10</b>	Number of motor 2 poles	A10 M2 POLES	2 to 14	2	4	
<b>R11</b>	Motor 2 (Capacity)	A11 M2-CAP	30HP or smaller : 0.01 to 45.00kW 40HP or larger : 0.01 to 800.00kW	0.01kW	*1)	
<b>R12</b>	(Rated current)	A12 M2-Ir	0.00 to 2000 A	0.01A	*1)	
<b>R13</b>	(Tuning)	A13 M2 TUN1	0 : Inactive 1 : Active (One time tuning of %R1 and %X ( on motor stopping mode )) 2 : Active (One time tuning of %R1, %X and I <sub>o</sub> ( on motor running mode ))	-	0	
<b>R14</b>	(On-line Tuning)	A14 M2 TUN2	0 : Inactive 1 : Active (Real time tuning of %R1 and %X)	-	0	
<b>R15</b>	(No-load current)	A15 M2-Io	0.00 to 2000 A	0.01A	*1)	
<b>R16</b>	(%R1 setting)	A16 M2-%R1	0.00 to 50.00 %	0.01%	*1)	
<b>R17</b>	(%X setting)	A17 M2-%X	0.00 to 50.00 %	0.01%	*1)	
<b>R18</b>	Slip compensation control 2	A18 SLIP COMP2	0.00 to +15.00 Hz	0.01Hz	0.00	

NOTES : \*1) Typical value of standard Fuji 4P motor. \*2) Percent shall be set according to FUNCTION CODE : P02 or A11, Motor capacity, Torque referenced here may not be obtainable when DATA CODE : 0 is selected for FUNCTION CODE : P02 or A11.

The functions in the yellow boxes can be set while the inverter is running. Other functions must be set while the inverter is stopped.

## User Functions

Function Code	Name	LCD monitor	Setting range	Min. unit	Factory setting	
					-30HP	40HP-
<b>U01</b>	Maximum compensation frequency during braking torque limit	U01 USER 01	0 to 65535	1	75	
<b>U02</b>	1st S-shape level at acceleration	U02 USER 02	1 to 50%	1	10	
<b>U03</b>	2nd S-shape level at acceleration	U03 USER 03	1 to 50%	1	10	
<b>U04</b>	1st S-shape level at deceleration	U04 USER 04	1 to 50%	1	10	
<b>U05</b>	2nd S-shape level at deceleration	U05 USER 05	1 to 50%	1	10	
<b>U08</b>	Main DC link (Initial value)	U08 USER 08	0 to 65535	1	XXXX	
<b>U09</b>	capacitor (Measured value)	U09 USER 09	0 to 65535	1	0	
<b>U10</b>	PC board capacitor powered on time	U10 USER 10	0 to 65535h	1	0	
<b>U11</b>	Cooling fan operating time	U11 USER 11	0 to 65535h	1	0	
<b>U13</b>	Magnetize current vibration damping gain	U13 USER 13	0 to 32767	1	819	410
<b>U15</b>	Slip compensation filter time constant	U15 USER 15	0 to 32767	1	556	546
<b>U23</b>	Integral gain of continuous operation at power failure	U23 USER 23	0 to 65535	1	1738	1000
<b>U24</b>	Proportional gain of continuous operation at power failure	U24 USER 24	0 to 65535	1	1024	1000
<b>U48</b>	Input phase loss protection	U48 USER 48	0, 1, 2	-	-75HP 0	100HP- 1
<b>U49</b>	RS-485 protocol selection	U49 USER 49	0, 1	-	0	
<b>U56</b>	Speed agreement (Detection width)	U56 USER 56	0 to 50%	1	10	
<b>U57</b>	/PG error (Delection timer)	U57 USER 57	0.0 to 10.0s	0.1	0.5	
<b>U58</b>	PG error selection	U58 USER 58	0, 1	-	1	
<b>U59</b>	Braking-resistor function select (up to 30HP) Manufacturer's function (40HP or more)	U59 USER 59	00 to A8 (HEX)	1	00	
<b>U60</b>	Regeneration avoidance at deceleration	U60 USER 60	0, 1	-	0	
<b>U61</b>	Voltage detect offset and gain adjustment	U61 USER 61	-30HP : 0 (Fixed.) 40HP- : 0, 1, 2	-	0	

The functions in the yellow boxes can be set while the inverter is running. Other functions must be set while the inverter is stopped.

# Protective Functions

# G11S/P11S

Function	Description		LED monitor
<b>Overcurrent protection (Short-circuit) (Ground fault)</b>	<ul style="list-style-type: none"> <li>Stops running to protect inverter from an overcurrent resulting from overload.</li> <li>Stops running to protect inverter from an overcurrent due to a short-circuit in the output circuit.</li> <li>Stops running to protect inverter from an overcurrent due to a ground fault in the output circuit.</li> <li>Stops running to protect inverter from an overcurrent resulting from ground fault in the output circuit by detecting zero-phase current.</li> </ul>	<ul style="list-style-type: none"> <li>40HP or larger model only</li> </ul>	During acceleration <b>OC 1</b>
			During deceleration <b>OC 2</b>
			While running at constant speed <b>OC 3</b>
			Ground fault <b>EF</b>
<b>Overvoltage protection</b>	<ul style="list-style-type: none"> <li>The inverter stops when it detects an overvoltage in the DC link circuit.</li> </ul>	<ul style="list-style-type: none"> <li>460V : 800V DC or more</li> <li>230V : 400V DC or more</li> <li>Protection is not assured if excess AC line voltage is applied inadvertently.</li> </ul>	During acceleration <b>OU 1</b>
			During deceleration <b>OU 2</b>
			While running at constant speed <b>OU 3</b>
<b>Incoming surge protection</b>	<ul style="list-style-type: none"> <li>Protects the inverter against surge voltage between the main circuit power line and ground.</li> <li>Protects the inverter against surge voltage in the main circuit power line.</li> </ul>	<ul style="list-style-type: none"> <li>The inverter may be tripped by some other protective function.</li> </ul>	
<b>Undervoltage protection</b>	<ul style="list-style-type: none"> <li>Stops the inverter when the DC link circuit voltage drops below undervoltage level.</li> </ul>	<ul style="list-style-type: none"> <li>460V : 360V DC (30HP or smaller), 375V DC (40HP or larger)</li> <li>230V : 180V DC (30HP or smaller), 186V DC (40HP or larger)</li> </ul>	<b>LU</b>
<b>Input phase loss protection</b>	<ul style="list-style-type: none"> <li>The inverter is protected from being damaged when open-phase fault occurs.</li> </ul>		<b>L1n</b>
<b>Overheat protection</b>	<ul style="list-style-type: none"> <li>Stops the inverter when it detects excess heat sink temperature in case of cooling fan failure or overload. This is also caused by short-circuit of terminals 13 and 11.</li> <li>Stops the inverter when it detects an abnormal rise in temperature in the inverter unit caused by insufficient ventilation in cubicles or an abnormal ambient temperature.</li> <li>This is also caused by short-circuit of terminals 13 and 11 (overcurrent of 20mA at terminal 13).</li> <li>When the built-in braking resistor overheats, the inverter stops discharging and running.</li> <li>Function data appropriate for the resistor type (built-in/external) must be set.</li> </ul>	<ul style="list-style-type: none"> <li>G11S : 10HP or smaller model only</li> </ul>	<b>OH 1</b>
			<b>OH 3</b>
			<b>dbH</b>
<b>Electronic thermal overload protection (Motor protection)</b>	<ul style="list-style-type: none"> <li>This function stops the inverter by detecting an inverter overload.</li> <li>This function stops the inverter by detecting an overload in a standard motor or inverter motor.</li> </ul>		<b>OLU</b>
			Motor 1 overload <b>OL 1</b>
			Motor 2 overload <b>OL 2</b>
<b>Fuse blown</b>	<ul style="list-style-type: none"> <li>When a blown fuse is detected, the inverter stops running.</li> </ul>	<ul style="list-style-type: none"> <li>40HP or larger model only</li> </ul>	<b>FUS</b>
<b>Stall prevention (Momentary overcurrent limitation)</b>	<ul style="list-style-type: none"> <li>When an output current exceeds the limit during acceleration, this function lowers output frequency to prevent the occurrence of an OC1 trip.</li> </ul>	<ul style="list-style-type: none"> <li>The stall prevention function can be disabled.</li> </ul>	
<b>Output phase loss error</b>	<ul style="list-style-type: none"> <li>If an unbalance of output circuits is detected during auto-tuning, this function issues an alarm (and stops the inverter).</li> </ul>		<b>Er 7</b>
<b>Active drive</b>	<ul style="list-style-type: none"> <li>During running in which acceleration is 60s or longer, this function increases the acceleration time to prevent the occurrence of an OLU trip.</li> </ul>	<ul style="list-style-type: none"> <li>The acceleration time can be prolonged up to three times the preset time.</li> </ul>	
<b>External alarm input</b>	<ul style="list-style-type: none"> <li>The inverter stops on receiving external alarm signals.</li> <li>This function is activated when the motor temperature rises where PTC thermistor is used for motor protection (H26: 1).</li> </ul>	<ul style="list-style-type: none"> <li>Use THR terminal function (digital input).</li> </ul>	<b>OH 2</b>
<b>Overspeed protection</b>	<ul style="list-style-type: none"> <li>Stops the inverter when the output frequency exceeds the rated maximum frequency by 20%.</li> </ul>		<b>OS</b>
<b>PG error</b>	<ul style="list-style-type: none"> <li>If disconnection occurs in pulse generator circuits, the inverter issues an alarm.</li> </ul>		<b>PG</b>
<b>Alarm output (for any fault)</b>	<ul style="list-style-type: none"> <li>The inverter outputs a relay contact signal when the inverter issued an alarm and stopped.</li> </ul>	<ul style="list-style-type: none"> <li>Output terminals: 30A, 30B, and 30C</li> <li>Use the RST terminal function for signal input.</li> <li>Even if main power input is turned off, alarm history and trip-cause data are retained.</li> </ul>	
<b>Alarm reset command</b>	<ul style="list-style-type: none"> <li>An alarm-stop state of the inverter can be cleared with the RESET key or by a digital input signal (RST).</li> </ul>		
<b>Alarm history memory</b>	<ul style="list-style-type: none"> <li>Store up to four instances of previous alarm data.</li> </ul>		
<b>Storage of data on cause of trip</b>	<ul style="list-style-type: none"> <li>The inverter can store and display details of the latest alarm history data.</li> </ul>		
<b>Memory error</b>	<ul style="list-style-type: none"> <li>The inverter checks memory data after power-on and when the data is written. If a memory error is detected, the inverter stops.</li> </ul>		<b>Er 1</b>
<b>KEYPAD panel communication error</b>	<ul style="list-style-type: none"> <li>If an error is detected in communication between the inverter and KEYPAD when the Keypad panel is being used, the inverter stops.</li> </ul>	<ul style="list-style-type: none"> <li>When operated by external signals, the inverter continues running. The alarm output (for any fault) is not output. Only Er2 is displayed.</li> </ul>	<b>Er 2</b>
<b>CPU error</b>	<ul style="list-style-type: none"> <li>If the inverter detects a CPU error caused by noise or some other factor, the inverter stops.</li> </ul>		<b>Er 3</b>
<b>Option communication error</b>	<ul style="list-style-type: none"> <li>If a checksum error or disconnection is detected during communication, the inverter issues an alarm.</li> </ul>		<b>Er 4</b>
<b>Option error</b>	<ul style="list-style-type: none"> <li>If a linkage error or other option error is detected, the inverter issues an alarm.</li> </ul>		<b>Er 5</b>
<b>Operation procedure error</b>	<ul style="list-style-type: none"> <li>Er6 is indicated only when the inverter is forcibly stopped by [STOP 1] or [STOP 2] operation in E01to E09 (Set value: 30 or 31).</li> </ul>		<b>Er 6</b>
<b>Output wiring error</b>	<ul style="list-style-type: none"> <li>This error is detected when the wiring on the inverter output is disconnected unwired on auto-tuning.</li> </ul>		<b>Er 7</b>
<b>Charging circuit alarm</b>	<ul style="list-style-type: none"> <li>This alarm is activated when the power supply is not applied to the main terminal L1/R or L3/T or charging-circuit relay is faulty.</li> </ul>	<ul style="list-style-type: none"> <li>40HP or larger model only</li> </ul>	<b>Er 7.</b>
<b>RS-485 communication error</b>	<ul style="list-style-type: none"> <li>If an RS-485 communication error is detected, the inverter issues an alarm.</li> </ul>		<b>Er 8</b>

NOTES : 1)Retaining alarm signal when auxiliary controll power supply is not used : If the inverter power supply is cut off while an internal alarm signal is being output, the alarm signal cannot be retained. 2)To issue the RESET command, press the  key on the KEYPAD panel or connect terminals RST and CM and disconnect them afterwards. 3)Fault history data is stored for the past four trips.

# External Dimensions

**Fig. 1**

FRNF25G11S-2UX to FRN001G11S-2UX  
FRNF50G11S-4UX,FRN001G11S-4UX

Unit:inch(mm)

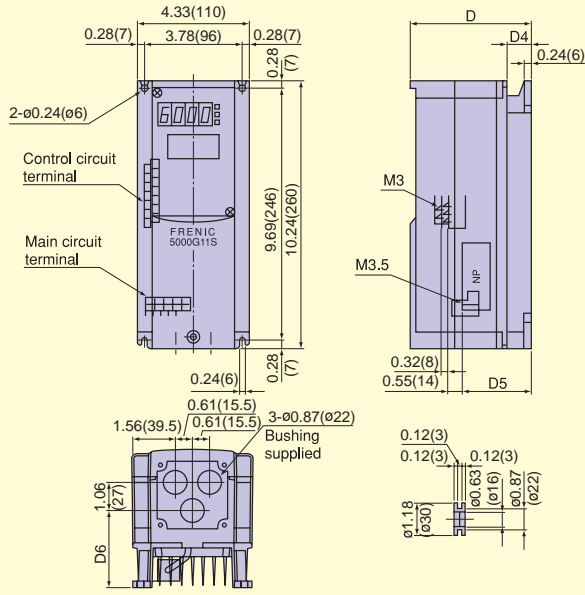

Type	D	D4	D5	D6
FRNF25G11S-2UX	5.12 (130)	1.44 (36.5)	3.15 (80)	2.85 (71.5)
FRNF50G11S-2UX				
FRNF50G11S-4UX				
FRN001G11S-2UX	5.71 (145)	2.03 (51.5)	3.74 (95)	3.41 (86.5)
FRN001G11S-4UX				

**Fig. 2**

FRN002G11S-2UX to FRN005G11S-2UX  
FRN002G11S-4UX to FRN005G11S-4UX

Unit:inch(mm)

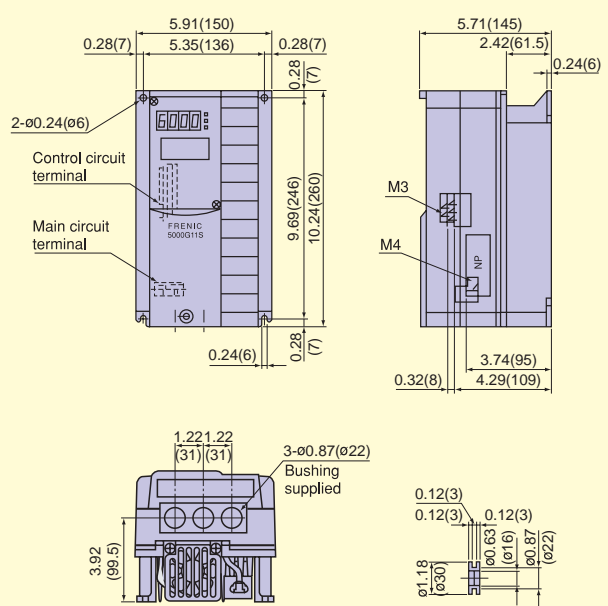

**Fig. 3**

FRN007G11S-2UX,FRN010G11S-2UX  
FRN007G11S-4UX,FRN010G11S-4UX  
FRN007P11S-2UX to FRN015P11S-2UX  
FRN007P11S-4UX to FRN015P11S-4UX

Unit:inch(mm)

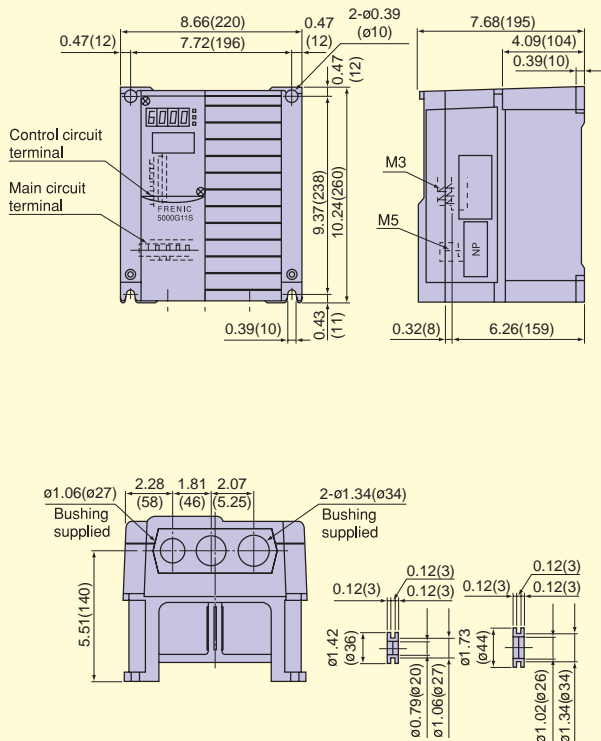

**Fig. 4**

FRN015G11S-2UX to FRN030G11S-2UX  
FRN015G11S-4UX to FRN030G11S-4UX  
FRN020P11S-2UX to FRN030P11S-2UX  
FRN020P11S-4UX to FRN030P11S-4UX

Unit:inch(mm)

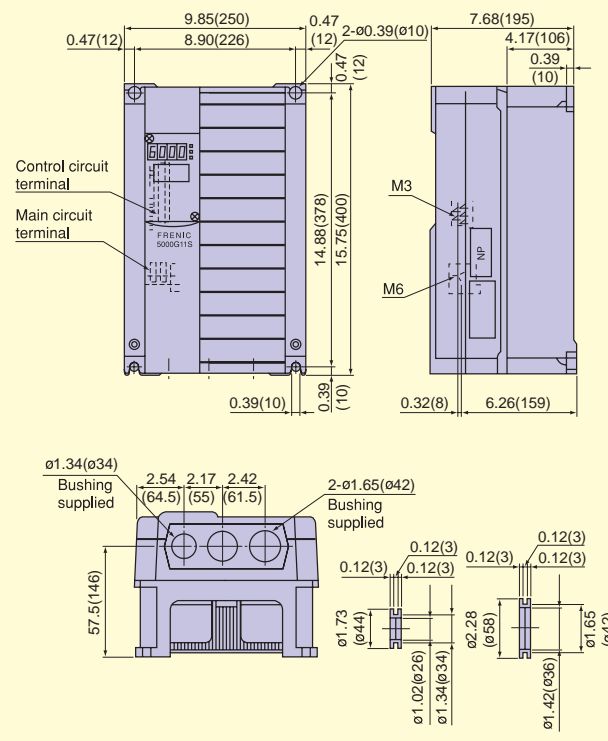





# Options

## Reactor, Filter, and Other Accessories

Name (Type)	Function	Mounting position
<b>Arrester</b> (CN23232) (CN2324E)	Suppresses induced lightning surges from power source , thus protecting all equipment connected the power source.	
<b>Radio noise reducing zero-phase reactor</b> (ACL-40B) (ACL-74B)	Reduces radio frequency noise. If the wiring between motor and inverter is shorter than 20m, use the ferrite ring in the power supply side. If longer than 20m, use it in the output side.	
<b>Power filter</b> (FHF-TA/□□/250) (FHF-TA/□□/500) (FHF-TB/□□/250) (FHF-TB/□□/500)	Prevents the noise generated from the inverter.  Suppresses radiation noise and induction noise generated from the output side wiring.	
<b>EMC compliant filter</b> (EFL-□□□SP-2) (EFL-□□□G11-4) (RF3□□□-F11)	This is a special filter which complies with the European EMC (Emission) Directive. This filter should be used together with a ferrite core. <i>Note: Other prerequisites must be fulfilled to ensure compliance with EMC Directives. Refer to this filters operation manual for details.</i>	
<b>Output circuit filter</b> (OFL-□□□□-□) (OFL-□□□□-4A)	Connected to the output circuit of inverters under low-noise operation with carrier frequency from 8 to 15kHz, 6kHz or higher for 40HP or larger inverters (OFL-□□□□-□), 0.75 to 15kHz, 0.75 to 10kHz for 100HP or larger inverters (OFL-□□□□-4A). This filter has the following functions: <ol style="list-style-type: none"> <li>① Suppressing fluctuation of motor terminal voltage. Protects the motor insulation from being damaged by surge voltage. (460V series)</li> <li>② Suppressing leakage current from output side wiring. (OFL-□□□□-□ only) Reduces the leakage current caused when several motors are operated in parallel or connected with long wiring. * Total wiring length should be less than 1300ft(400m).</li> <li>③ Suppressing radial noise or inductive noise from output side wiring. Effective noise suppression device for long wiring applications such as plant. <i>Note: When connecting OFL-□□□□-□, be sure to set the carrier frequency F26 at 8kHz or over.</i></li> </ol>	
<b>DC REACTOR(DCR)</b> (DCR4-□□□) (DCR2-□□□)	[Use the DCR to normalize the power supply in the following cases.] <ol style="list-style-type: none"> <li>① The power transformer capacity is 500kVA or over and exceeds the inverter rated capacity by 10 times.</li> <li>② The inverter and a thyristor converter are connected with the same transformer. * Check if the thyristor converter uses a commutation reactor. If not, AC reactor must be connected to the power supply side.</li> <li>③ Overvoltage trip occurs due to open/close of the phase-advancing capacitor for the power supply lines.</li> <li>④ The voltage unbalance exceeds 2%.</li> </ol> $\text{Voltage unbalance (\%)} = \frac{\text{Max. voltage [V]} - \text{Min. Voltage [V]}}{\text{Three-phase average voltage [V]}} \times 67$ <p>[For improving input power-factor, reducing harmonics]</p> <ul style="list-style-type: none"> <li>• Used to reduce input harmonic current (correcting power-factor)</li> <li>• For the resultant effects, refer to the appended guidelines.</li> </ul>	
<b>Surge absorber</b> (Surge suppressor) (S2-A-0) (S1-B-0)	S2-A-0: for magnetic contactor S1-B-0: for mini control relay, or timer	
<b>Frequency meter</b> (TRM-45) (FM-60)	Analog frequency meter TRM-45: 1.77inch(45mm) square FM-60 : 2.36inch(60mm) square	
<b>Frequency setting device</b> (RJ-13) (WA3W-1kΩ)	Frequency setting potentiometer (mounted externally)	



# Options

## Braking unit, Braking resistor

Power supply voltage	Inverter				Option				G11S Max. braking torque (%)	Continuous braking (100% torque conversion value)				P11S Max. braking torque (%)	Continuous braking (100% torque conversion value)											
	G11S		P11S		Braking unit		Braking resistor			Braking time (s)	Discharging capability (kW)	Duty cycle (%)	Average loss (HP)		Braking time (s)	Discharging capability (kW)	Duty cycle (%)	Average loss (HP)								
	Motor (HP)	Inverter type	Motor (HP)	Inverter type	Type	Q'ty	Type	Q'ty																		
Three-phase 230V	1/4	FRNF25G11S-2UX	—	—	—	—	—	1	150%	90	9	37	0.050	100%	—	—	—	—								
	1/2	FRNF50G11S-2UX	—	—	—	—	—	1		45	9	22	0.059													
	1	FRNF001G11S-2UX	—	—	—	—	—	1		45	17	18	0.091													
	2	FRNF002G11S-2UX	—	—	—	—	—	1		45	34	10	0.101													
	3	FRNF003G11S-2UX	—	—	—	—	—	1		30	33	7	0.103													
	5	FRNF005G11S-2UX	7.5	FRNF007P11S-2UX	—	—	—	1		20	37	5	0.125						15	37	3.5	0.125				
	7.5	FRNF007G11S-2UX	10	FRNF010P11S-2UX	—	—	—	1		20	55	5	0.185										15	55	3.5	0.185
	10	FRNF010G11S-2UX	15	FRNF015P11S-2UX	—	—	—	1		10	37	5	0.252													
	15	FRNF015G11S-2UX	20	FRNF020P11S-2UX	BU22-2C	1	DB11-2	1		10	55	5	0.369						7	55	3.5	0.369				
	20	FRNF020G11S-2UX	25	FRNF025P11S-2UX		1	DB15-2	1		10	75	5	0.503										8	75	4	0.503
	25	FRNF025G11S-2UX	30	FRNF030P11S-2UX		1	DB18.5-2	1		10	92	5	0.621													
	30	FRNF030G11S-2UX	40	FRNF040P11S-2UX	1	DB22-2	1	8		88	5	0.738	6						88	3.5	0.738					
	40	FRNF040G11S-2UX	50	FRNF050P11S-2UX	BU37-2C	1	DB30-2C	1		10	150	10										2.012	8	150	8	2.012
	50	FRNF050G11S-2UX	60	FRNF060P11S-2UX		1	DB37-2C	1		10	185	10										2.481				
	60	FRNF060G11S-2UX	75	FRNF075P11S-2UX	BU55-2C	1	DB45-2C	1		10	225	10	3.017						8	225	8	3.017				
75	FRNF075G11S-2UX	100	FRNF100P11S-2UX	1		DB55-2C	1	10	275	10	3.688	7	275	7	3.688											
100	FRNF100G11S-2UX	125	FRNF125P11S-2UX	BU90-2C	1	DB75-2C	1	10	375	10	5.029					8	375	8	5.029							
125	FRNF125G11S-2UX	150	FRNF150P11S-2UX		1	DB90-2C	1	10	450	10	6.035									8	450	8	6.035			
Three-phase 460V	1/2	FRNF50G11S-4UX	—	—	—	—	—	1	150%	45	9	22	0.059	100%	—	—	—	—								
	1	FRNF001G11S-4UX	—	—	—	—	—	1		45	17	18	0.091													
	2	FRNF002G11S-4UX	—	—	—	—	—	1		45	34	10	0.101													
	3	FRNF003G11S-4UX	—	—	—	—	—	1		30	33	7	0.103													
	5	FRNF005G11S-4UX	7.5	FRNF007P11S-4UX	—	—	—	1		20	37	5	0.125						15	37	3.5	0.125				
	7.5	FRNF007G11S-4UX	10	FRNF010P11S-4UX	—	—	—	1		20	55	5	0.185										15	55	3.5	0.185
	10	FRNF010G11S-4UX	15	FRNF015P11S-4UX	—	—	—	1		10	38	5	0.252													
	15	FRNF015G11S-4UX	20	FRNF020P11S-4UX	BU22-4C	1	DB11-4	1		10	55	5	0.369						7	55	3.5	0.369				
	20	FRNF020G11S-4UX	25	FRNF025P11S-4UX		1	DB15-4	1		10	75	5	0.503										8	75	4	0.503
	25	FRNF025G11S-4UX	30	FRNF030P11S-4UX		1	DB18.5-4	1		10	93	5	0.621													
	30	FRNF030G11S-4UX	40	FRNF040P11S-4UX	1	DB22-4	1	8		88	5	0.738	6						88	3	0.738					
	40	FRNF040G11S-4UX	50	FRNF050P11S-4UX	BU37-4C	1	DB30-4C	1		10	150	10										2.012	8	150	8	2.012
	50	FRNF050G11S-4UX	60	FRNF060P11S-4UX		1	DB37-4C	1		10	185	10										2.481				
	60	FRNF060G11S-4UX	75	FRNF075P11S-4UX	BU55-4C	1	DB45-4C	1		10	225	10	3.017						8	225	8	3.017				
	75	FRNF075G11S-4UX	100	FRNF100P11S-4UX		1	DB55-4C	1		10	275	10	3.688										7	275	7	3.688
	100	FRNF100G11S-4UX	125	FRNF125P11S-4UX	BU90-4C	1	DB75-4C	1		10	375	10	5.029						8	375	8	5.029				
	125	FRNF125G11S-4UX	150	FRNF150P11S-4UX		1	DB110-4C	1		10	450	10	6.035													
	150	FRNF150G11S-4UX	200	FRNF200P11S-4UX	BU132-4C	1	DB110-4C	1		10	550	10	7.376						8	550	8	7.376				
	200	FRNF200G11S-4UX	250	FRNF250P11S-4UX		1	DB132-4C	1		10	665	10	8.918										8	665	8	8.918
	250	FRNF250G11S-4UX	300	FRNF300P11S-4UX		1	DB160-4C	1		10	800	10	10.728													
	300	FRNF300G11S-4UX	350	FRNF350P11S-4UX	BU220-4C	1	DB200-4C	1		10	1000	10	13.410						9	1000	9	13.410				
	350	FRNF350G11S-4UX	400	FRNF400P11S-4UX		1	DB220-4C	1		10	1100	10	14.751										8	1100	8	14.751
	400	FRNF400G11S-4UX	450	FRNF450P11S-4UX		2	DB160-4C	2		11	1600	11	21.456													
	450	FRNF450G11S-4UX	500	FRNF500P11S-4UX	2	DB160-4C	2	10		1600	10	21.456	9						1600	9	21.456					
	500	FRNF500G11S-4UX	600	FRNF600P11S-4UX	2	DB200-4C	2	11		2000	11	26.820										10	2000	10	26.820	
	600	FRNF600G11S-4UX	700	FRNF700P11S-4UX	2	DB200-4C	2	10		2000	10	26.820	9						2000	9	26.820					
	—	—	800	FRNF800P11S-4UX	2	DB200-4C	2	—		—	—	—														8

NOTES: 1) Each model of the P11S series uses options that are one-class smaller than the options for the G11S series of the same capacity.  
2) The braking time and duty cycle (%) are calculated as the rated-torque braking used for deceleration.

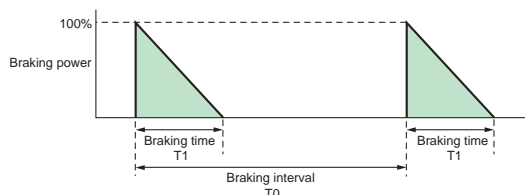

$$\bullet \text{ Duty cycle (\%)} = \frac{T1}{T0} \times 100 \text{ [\%]}$$

[Procedure for selecting options]

All three conditions listed below must be satisfied.

- ① The maximum braking torque does not exceed the value shown in the table.
- ② The energy discharged in the resistor for each braking (the area of the triangle shown in the above figure) does not exceed the discharging capability (kW) in the table.
- ③ The average loss (energy discharged in the resistor divided by a braking interval) does not exceed the average loss (kW) shown in the table.

Name (type)	Dimensions												
Braking unit	Fig.A												
			Fig.B										
					Fig.C								
			Type	Fig.			Dimensions [inch(mm)]						Weight [lbs(kg)]
							W	W1	H	H1	H2	D	
	230V	BU3-185-2	A	See Fig. A						2.4(1.1)			
		BU3-220-2		See Fig. A						2.6(1.2)			
		BU37-2C		B	5.91(150)	3.94(100)	9.45(240)	8.86(225)	8.27(210)	6.3(160)	8.8(4.0)		
		BU55-2C		C	9.06(230)	5.12(130)	9.45(240)	8.86(225)	8.27(210)	6.3(160)	13(6.0)		
		BU90-2C	9.84(250)		5.91(150)	14.57(370)	13.98(355)	13.39(340)	6.3(160)	20(9.0)			
460V	BU3-220-4	A	See Fig. A						2.4(1.1)				
	BU37-4C	C	5.91(150)	3.94(100)	11.02(280)	10.43(265)	9.84(250)	6.3(160)	8.8(4.0)				
	BU55-4C		9.06(230)	5.12(130)	11.02(280)	10.43(265)	9.84(250)	6.3(160)	12(5.5)				
	BU90-4C		9.84(250)	5.91(150)	11.02(280)	10.43(265)	9.84(250)	6.3(160)	12(5.5)				
	BU132-4C		9.84(250)	5.91(150)	14.57(370)	13.98(355)	13.39(340)	6.3(160)	20(9.0)				
	BU220-4C		9.84(250)	5.91(150)	17.72(450)	17.13(435)	16.54(420)	6.3(160)	29(13)				

Name (type)	Dimensions												
Braking resistor	Fig.A												
			Fig.B										
					Fig.C								
			Type	Fig.			Dimensions [inch(mm)]						Weight [lbs(kg)]
							W	W1	H	H1	D		
	230V	DB0.75-2	A	2.52(64)	-	12.2(310)	11.61(295)	2.64(67)	2.9(1.3)				
		DB2.2-2		2.99(76)	-	13.58(345)	13.07(332)	3.7(94)	4.4(2.0)				
		DB3.7-2	B	5.58(142)	3.54(90)	17.72(450)	16.93(430)	2.66(67.5)	9.9(4.5)				
		DB7.5-2		6.14(156)		15.35(390)	14.57(370)	3.54(90)	11(5.0)				
		DB11-2	C	5.58(142)	2.91(74)	16.93(430)	16.34(415)	6.3(160)	15(6.9)				
		DB15-2				20.08(510)	19.49(495)			19(8.7)			
		DB18.5-2											
		DB22-2	D	15.75(400)	14.49(368)	25.98(660)	24.72(628)	5.51(140)	22(10)				
		DB30-2C				9.45(240)	49(22)						
		DB37-2C						11.14(283)	9.45(240)	17.32(440)	77(35)		
		DB45-2C				21.65(550)	20.47(520)					71(32)	
		DB55-2C											
		DB75-2C	E	17.72(450)	16.54(420)	11.14(283)	9.45(240)	17.32(440)	77(35)				
		DB110-2C		21.65(550)	20.47(520)				71(32)				
	460V	DB0.75-4	A	2.52(64)	-	12.2(310)	11.61(295)	2.64(67)	2.9(1.3)				
		DB2.2-4				18.5(470)	17.91(455)	3.7(94)	4.4(2.0)				
		DB3.7-4	B	5.58(142)	2.91(74)	18.5(470)	17.91(455)	2.64(67)	3.7(1.7)				
		DB5.5-4				20.47(520)	19.49(495)	2.64(67)	11(5.0)				
		DB7.5-4	C	5.58(142)	2.91(74)	16.93(430)	16.34(415)	6.3(160)	15(6.9)				
		DB11-4				20.08(510)	19.49(495)			19(8.7)			
		DB15-4											
		DB18.5-4	D	16.54(420)	15.28(388)	25.98(660)	24.72(628)	5.51(140)	24(11)				
		DB22-4				9.45(240)	46(21)						
		DB30-4C						11.14(283)	9.45(240)	17.32(440)	95(43)		
		DB37-4C				21.65(550)	20.47(520)					66(30)	
		DB45-4C											
		DB55-4C	E	25.59(650)	24.41(620)	11.14(283)	9.45(240)	17.32(440)	90(41)				
		DB75-4C				29.53(750)	28.35(720)	126(57)					
		DB110-4C							23.62(600)	22.44(570)	163(74)		
		DB132-4C											
	DB160-4C												
	DB200-4C												
	DB220-4C*												

\* Note: The braking resistor type DB220-4C use two braking resistors.

Name (type)	Dimensions									
Radio noise reducing zero-phase reactor (ACL-40B)(ACL-74B)	Fig.A									
			Fig.B							
	Type	Fig.			Dimensions [inch(mm)]					
					W	W1	H	H1	D	
	ACL-40B	1	4	2.0, 3.5, 5.5						
	ACL-74B	2	2	8, 14						
				1	4	8, 14				
		2	2			22, 38, 60, 5.5 x 2, 8 x 2, 14 x 2, 22 x 2				
				4	1	100, 150, 200, 250, 325, 38 x 2, 60 x 2, 100 x 2, 150 x 2				

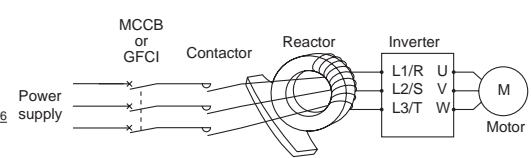

Reactor type	Q'ty	No. of turns	Recommended wire size [mm <sup>2</sup> ]	
ACL-40B	1	4	2.0, 3.5, 5.5	
	2	2	8, 14	
ACL-74B	1	4	8, 14	
	2	2	22, 38, 60, 5.5 x 2, 8 x 2, 14 x 2, 22 x 2	
	4	1	100, 150, 200, 250, 325, 38 x 2, 60 x 2, 100 x 2, 150 x 2	

# Option cards and other options

Name (type)	Function	Specifications		
<b>Relay output card (OPC-G11S-RY)</b>	<ul style="list-style-type: none"> <li>Includes four relay output circuits.</li> <li>Converts transistor output signals from inverter control output terminals Y1 to Y4 to relay (SPDT) output signals.</li> </ul>			
<b>Digital I/O interface card (OPC-G11S-DIO)</b>	<ul style="list-style-type: none"> <li>For setting frequency using a binary code.</li> <li>For monitoring frequency, output current, and output voltage using a binary code.</li> <li>For input and output of other individual signals.</li> </ul>			
<b>Analog I/O interface card (OPC-G11S-AIO)</b>	<ul style="list-style-type: none"> <li>For setting a torque limit value using an input analog signal.</li> <li>For input of auxiliary signal to set frequency.</li> <li>For analog monitoring of inverter output frequency, output current, and torque.</li> </ul>			
<b>T-link interface card (OPC-G11S-TL)</b>	<ul style="list-style-type: none"> <li>For setting a frequency.</li> <li>For setting, reading, and storing function data for function codes.</li> <li>For setting operation commands (FWD, REV, RST, etc.).</li> <li>For monitoring the operation status.</li> <li>For reading trip information.</li> </ul>	<ul style="list-style-type: none"> <li>Used together with MICREX-F series PLC.</li> </ul>		
<b>Open bus card</b>	It is an optional card conforming to various open buses. The following operation can be made from the personal computer and PLC. <ul style="list-style-type: none"> <li>Setting of running frequency</li> <li>Setting of operation command (FWD,REV,RST,etc.)</li> <li>Setting/reading of data code of each function code</li> <li>Monitoring running frequency and operation status</li> </ul>	Correspondent bus	Option type	
		PROFIBUS-DP DeviceNet Modbus Plus Interbus-S CAN open	OPC-G11S-PDP OPC-G11S-DEV OPC-G11S-MBP OPC-G11S-IBS OPC-G11S-COP	
<b>RS-232C communication adaptor (OPC-G11S-PC)</b>	The RS-232C communication can be done by connecting it to the keypad panel on the main body of the inverter.			
<b>Personal computer loader</b>	<ul style="list-style-type: none"> <li>The operation status monitoring and the parameter setting can be made through the inverter's RS-485 interface from the host personal computer.</li> <li>The parameter can be read and written collectively or individually.</li> <li>Comparison of two arbitrary parameters.</li> <li>Monitor of output frequency, output current, and operation status of inverter.</li> <li>Monitor of alarm history and operation information on alarm.</li> </ul>	Communication <ul style="list-style-type: none"> <li>Physical level : EIA-RS-485</li> <li>The number of units connected : Maximum 31 inverters</li> <li>Synchronous method : start-stop synchronization</li> <li>Transmission method : half duplex</li> </ul>		
<b>PG feedback card (OPC-G11S-PG)</b>	<ul style="list-style-type: none"> <li>For performing PG vector control using feedback signals obtained from a PG.</li> </ul>	Applicable Pulse Encoder specification: • 100 to 3000P/R • A, B, Z phase • 12V or 15V		
<b>PG feedback card (OPC-G11S-PG2)</b>	<ul style="list-style-type: none"> <li>For performing PG vector control using feedback signals obtained from a PG.</li> </ul>	Applicable Pulse Encoder specification: • 100 to 3000P/R • A, B, Z phase • 5V		
<b>Synchronized operation card (OPC-G11S-SY)</b>	<ul style="list-style-type: none"> <li>Speed control by pulse train input can be made.</li> </ul>	Applicable Pulse Encoder specification: • 20 to 3000P/R • A, B, Z phase • 12V or 15V		
<b>Extension cable for keypad panel (CBIII-10R-□□□)</b>	Connects the keypad panel to an inverter unit. Three cable types are available: straight 6.56ft(2m), curled 3.28ft(1m), and curled 6.56ft(2m). The curled 3.28ft(1m) cable can be extended up to 16.4ft(5m), and the curled 6.56ft(2m) cable up to 32.8ft(10m). Note: Cables once extended to the maximum length do not return to their original length.	Type	Nominal length	Maximum length
		CBIII-10R-2S	6.56ft(2m)	6.56ft(2m)
		CBIII-10R-1C	3.28ft(1m)	16.4ft(5m)
		CBIII-10R-2C	6.56ft(2m)	32.8ft(10m)
<b>NEMA1 cover kit</b>	<ul style="list-style-type: none"> <li>Used to put 40HP or larger models to change its enclosure of IP00 into that of NEMA1.</li> </ul>	Type	Applicable inverter type	
		NEMA1-30G11-2	FRN040G11S-2UX	
		NEMA1-55G11-2	FRN050G11S-2UX FRN075G11S-2UX	
		NEMA1-75G11-2	FRN100G11S-2UX	
		NEMA1-90G11-2	FRN125G11S-2UX	
		NEMA1-30G11-4	FRN040G11S-4UX	
		NEMA1-55G11-4	FRN050G11S-4UX FRN075G11S-4UX	
		NEMA1-75G11-4	FRN100G11S-4UX	
		NEMA1-110G11-4	FRN125G11S-4UX FRN150G11S-4UX	
		NEMA1-160G11-4	FRN200G11S-4UX FRN250G11S-4UX	
		NEMA1-220G11-4	FRN300G11S-4UX FRN350G11S-4UX	
<b>Mounting adapter for external cooling (PBG11-□□□)</b>	<ul style="list-style-type: none"> <li>Used to put the cooling fan section of the inverter outside the panel.</li> <li>Only applicable to 30HP and below inverters. (40HP and above inverters can be modified to external cooling type by replacing the mounting bracket, as standard.)</li> </ul>	Type	Applicable inverter type	
		PBG11-0.75	FRNF50G11S-4UX to FRN001G11S4UX FRNF25G11S-2UX to FRN001G11S-2UX	
		PBG11-3.7	FRN002G11S-4UX to FRN005G11S-4UX FRN002G11S-2UX to FRN005G11S-2UX	
		PBG11-7.5	FRN007G11S4UX, 2UX to FRN010G11S-4UX, 2UX FRN007P11S-4UX, 2UX to FRN015P11S-4UX, 2UX	
		PBG11-22	FRN015G11S-4UX, 2UX to FRN030G11S-4UX, 2UX FRN020P11-4UX, 2UX to FRN030P11S-4UX, 2UX	
<b>Panel-mount adapter (MAG9-□□□)</b>	Used to put an FRN-G11S inverter to be mounted in panel holes that were used to mount an FVR-G7S inverter.	Type	Applicable inverter type	
		MAG9-3.7	FRNF50G11S-4UX to FRN005G11S-4UX FRNF50G11S-2UX to FRN005G11S-2UX	
		MAG9-7.5	FRN007G11S-4UX to FRN010G11S-4UX FRN007P11S-2UX to FRN010G11S-2UX	
		MAG9-22	FRN015G11S-4UX to FRN030G11S-4UX FRN015G11S-2UX to FRN030G11S2UX	

# Wiring equipment

Power supply voltage	Nominal applied motors [HP]	Inverter type		MCCB or GFCI Rated current (A)		Magnetic contactor (MC)			Recommended wire size (mm <sup>2</sup> )													
		G11S series	P11S series	With DCR	Without reactor	MC1 for input circuit		MC2 for output circuit	Input circuit [L1/R,L2/S,L3/T]		Output circuit [U,V,W]		DCR circuit [P1,P(+)]	DB circuit [P(+),DB,N(-)]								
						With DCR	Without reactor		With DCR	Without reactor	G11S	P11S										
Three-phase 230V	1/4	FRNF25G11S-2UX	—	5	5	SC-05	SC-05	SC-05	2.0	2.0	2.0	—	2.0	2.0								
	1/2	FRNF50G11S-2UX																				
	1	FRN001G11S-2UX																				
	2	FRN002G11S-2UX		10	15																	
	3	FRN003G11S-2UX																				
	5	FRN005G11S-2UX		20	30																	
	7.5	FRN007G11S-2UX		FRN007P11S-2UX	30		50	SC-5-1	SC-N1	SC-4-0	2.0	2.0	2.0		—	2.0						
	10	FRN010G11S-2UX		FRN010P11S-2UX	40		75	SC-5-1	SC-N2	SC-5-1	3.5	8.0	—		3.5	—	3.5					
	15	FRN015G11S-2UX		FRN015P11S-2UX	50		100	SC-N1	SC-N2S	SC-N1	5.5	14	—		5.5	8.0	8.0					
	20	FRN020G11S-2UX		FRN020P11S-2UX	75		125	SC-N2	SC-N3	SC-N2	8.0	22	8.0		8.0	14	14					
	25	FRN025G11S-2UX		FRN025P11S-2UX	100		150	SC-N2S	SC-N4	SC-N2S	14	38	14		14	22	22					
	30	FRN030G11S-2UX		FRN030P11S-2UX									175		SC-N5	SC-N3	—	—	14	—	—	—
	40	FRN040G11S-2UX		FRN040P11S-2UX									200		SC-N4	SC-N7	SC-N4	38	60	38	38	38
	50	FRN050G11S-2UX		FRN050P11S-2UX	175		250	SC-N5	SC-N8	SC-N5	38	100	—		—	60	60					
	60	FRN060G11S-2UX		FRN060P11S-2UX	200		300	SC-N7	SC-N7	SC-N7	60		38		—	—	100	100				
	75	FRN075G11S-2UX		FRN075P11S-2UX	250		350	SC-N8	SC-N11	SC-N8	100		100		100	—	100	100				
	100	FRN100G11S-2UX		FRN100P11S-2UX	350		—	SC-N11	—	SC-N10	150	—	—		100	150	150	150				
125	FRN125G11S-2UX	FRN125P11S-2UX	400	—	SC-N11	—							150	—	150	150	200	200				
150	FRN150P11S-2UX	FRN150P11S-2UX	500	—	SC-N12	—							SC-N12	200	—	200	250	250	250			
Three-phase 460V	1/2	FRNF50G11S-4UX	—	5	5	SC-05	SC-05	SC-05	2.0	2.0	2.0	—	2.0	2.0								
	1	FRN001G11S-4UX																				
	2	FRN002G11S-4UX																				
	3	FRN003G11S-4UX		10	15																	
	5	FRN005G11S-4UX																				
	7.5	FRN007G11S-4UX		FRN007P11S-4UX	15		30	SC-4-0	SC-4-0	2.0	2.0	2.0	—		2.0							
	10	FRN010G11S-4UX		FRN010P11S-4UX	20		40	SC-5-1	SC-5-1	SC-5-1	3.5	8.0	—		3.5	—	3.5					
	15	FRN015G11S-4UX		FRN015P11S-4UX	30		50	SC-N1	SC-N1	SC-N1	5.5	14	5.5		5.5	8.0	8.0					
	20	FRN020G11S-4UX		FRN020P11S-4UX	40		75	SC-N1	SC-N2S	SC-N1	5.5	14	8.0		5.5	8.0	8.0					
	25	FRN025G11S-4UX		FRN025P11S-4UX	50		100	SC-N2	SC-N3	SC-N2	8.0	22	14		14	22	22					
	30	FRN030G11S-4UX		FRN030P11S-4UX									125		SC-N2S	SC-N2S	14	22	14	14	22	22
	40	FRN040G11S-4UX		FRN040P11S-4UX									150		SC-N3	SC-N4	SC-N3	22	38	22	22	38
	50	FRN050G11S-4UX		FRN050P11S-4UX	100		150	SC-N4	SC-N5	SC-N4	38	60	38		38	38	38					
	60	FRN060G11S-4UX		FRN060P11S-4UX									200		SC-N5	SC-N5	38	60	38	38	38	38
	75	FRN075G11S-4UX		FRN075P11S-4UX									250		SC-N7	SC-N7	SC-N7	60	100	100	100	100
	100	FRN100G11S-4UX		FRN100P11S-4UX	175		—	SC-N7	—	SC-N8	100	—	60		60	60	60					
	125	FRN125G11S-4UX		FRN125P11S-4UX	200								SC-N8		SC-N8	SC-N8	100	100	100	150	150	
	150	FRN150G11S-4UX		FRN150P11S-4UX	250								SC-N11	SC-N11	SC-N11	150	150	150	150	150		
	200	FRN200G11S-4UX		FRN200P11S-4UX	300		—	SC-N12	—	SC-N12	200	—	200	200	250	250						
	250	FRN250G11S-4UX		FRN250P11S-4UX	350								SC-N12	SC-N12	SC-N12	200	200	200	250	250		
	300	FRN300G11S-4UX		FRN300P11S-4UX	500								SC-N14	SC-N14	SC-N14	250	250	250	325	325		
	350	FRN350G11S-4UX		FRN350P11S-4UX	600		700	SC-N14	—	SC-N14	150×2	200×2	150×2	150×2	200×2	200×2						
	400	FRN400G11S-4UX		FRN400P11S-4UX									600	SC-N16	SC-N16	SC-N16	250×2	250×2	250×2	325×2	325×2	
450	FRN450G11S-4UX	FRN450P11S-4UX	700	—		—							—	250×2	—	—	—	—	—			
500	FRN500G11S-4UX	FRN500P11S-4UX	800	1000	—	—	—	325×2	—	250×2	250×2	325×2	325×2									
600	FRN600G11S-4UX	FRN600P11S-4UX	1000							—	—	—	325×2	—	—	—	—					
700	FRN700P11S-4UX	FRN700P11S-4UX	1200							—	—	—	—	—	—	—	—					
800	FRN800P11S-4UX	FRN800P11S-4UX	1200	—	—	—	—	—	—	—	—	—										

**NOTES :**

- For molded-case circuit breakers (MCCB) and a ground-fault circuit interrupter(GFCI), the required frame type and series depend on the facility transformer capacity and other factors. When selecting optimal breakers, refer to the relevant technical data.
- Also select the rated sensitive current of GFCI utilizing the technical data.
- The recommended wire sizes are based on the condition that the temperature inside the panel does not exceeds 50°C(122°F).
- The above wires are 600V H1V insulated cables (75°C(167°F)).
- Data in the above table may differ for different conditions (ambient temperature, power supply voltage, and other factors).

\*Contact Fuji Electric FA.

## To all our customers who purchase Fuji Electric FA Components & Systems' products:

Please take the following items into consideration when placing your order.

When requesting an estimate and placing your orders for the products included in these materials, please be aware that any items such as specifications which are not specifically mentioned in the contract, catalog, specifications or other materials will be as mentioned below.

In addition, the products included in these materials are limited in the use they are put to and the place where they can be used, etc., and may require periodic inspection. Please confirm these points with your sales representative or directly with this company.

Furthermore, regarding purchased products and delivered products, we request that you take adequate consideration of the necessity of rapid receiving inspections and of product management and maintenance even before receiving your products.

### 1. Free of Charge Warranty Period and Warranty Range

#### 1-1 Free of charge warranty period

- (1) The product warranty period is "1 year from the date of purchase" or 18 months from the manufacturing date imprinted on the name plate, whichever date is earlier.
- (2) However, in cases where the use environment, conditions of use, use frequency and times used, etc., have an effect on product life, this warranty period may not apply.
- (3) Furthermore, the warranty period for parts restored by Fuji Electric's Service Department is "6 months from the date that repairs are completed."

#### 1-2 Warranty range

- (1) In the event that breakdown occurs during the product's warranty period which is the responsibility of Fuji Electric, Fuji Electric will replace or repair the part of the product that has broken down free of charge at the place where the product was purchased or where it was delivered. However, if the following cases are applicable, the terms of this warranty may not apply.
  - 1) The breakdown was caused by inappropriate conditions, environment, handling or use methods, etc. which are not specified in the catalog, operation manual, specifications or other relevant documents.
  - 2) The breakdown was caused by the product other than the purchased or delivered Fuji's product.
  - 3) The breakdown was caused by the product other than Fuji's product, such as the customer's equipment or software design, etc.
  - 4) Concerning the Fuji's programmable products, the breakdown was caused by a program other than a program supplied by this company, or the results from using such a program.
  - 5) The breakdown was caused by modifications or repairs affected by a party other than Fuji Electric.
  - 6) The breakdown was caused by improper maintenance or replacement using consumables, etc. specified in the operation manual or catalog, etc.
  - 7) The breakdown was caused by a chemical or technical problem that was not foreseen when making practical application of the product at the time it was purchased or delivered.
  - 8) The product was not used in the manner the product was originally intended to be used.
  - 9) The breakdown was caused by a reason which is not this company's responsibility, such as lightning or other disaster.
- (2) Furthermore, the warranty specified herein shall be limited to the purchased or delivered product alone.
- (3) The upper limit for the warranty range shall be as specified in item (1) above and any damages (damage to or loss of machinery or equipment, or lost profits from the same, etc.) consequent to or resulting from breakdown of the purchased or delivered product shall be excluded from coverage by this warranty.

#### 1-3. Trouble diagnosis

As a rule, the customer is requested to carry out a preliminary trouble diagnosis. However, at the customer's request, this company or its service network can perform the trouble diagnosis on a chargeable basis. In this case, the customer is asked to assume the burden for charges levied in accordance with this company's fee schedule.

### 2. Exclusion of Liability for Loss of Opportunity, etc.

Regardless of whether a breakdown occurs during or after the free of charge warranty period, this company shall not be liable for any loss of opportunity, loss of profits, or damages arising from special circumstances, secondary damages, accident compensation to another company, or damages to products other than this company's products, whether foreseen or not by this company, which this company is not be responsible for causing.

### 3. Repair Period after Production Stop, Spare Parts Supply Period (Holding Period)

Concerning models (products) which have gone out of production, this company will perform repairs for a period of 7 years after production stop, counting from the month and year when the production stop occurs. In addition, we will continue to supply the spare parts required for repairs for a period of 7 years, counting from the month and year when the production stop occurs. However, if it is estimated that the life cycle of certain electronic and other parts is short and it will be difficult to procure or produce those parts, there may be cases where it is difficult to provide repairs or supply spare parts even within this 7-year period. For details, please confirm at our company's business office or our service office.

### 4. Transfer Rights

In the case of standard products which do not include settings or adjustments in an application program, the products shall be transported to and transferred to the customer and this company shall not be responsible for local adjustments or trial operation.

### 5. Service Contents

The cost of purchased and delivered products does not include the cost of dispatching engineers or service costs. Depending on the request, these can be discussed separately.

### 6. Applicable Scope of Service

The above contents shall be assumed to apply to transactions and use of this company's products within the nation of Japan. Please discuss transactions and use outside Japan separately with the local supplier where you purchased the products, or with this company.





## NOTES

### In running general-purpose motors

- **Driving a 460V general-purpose motor**  
When driving a 460V general-purpose motor with an inverter, damage to the insulation of the motor may occur. Use an output circuit filter (OFL) if necessary after checking with the motor manufacturer. Fuji's motors do not require the use of output circuit filters because of their reinforced insulation.
- **Torque characteristics and temperature rise**  
When the inverter is used to run a general-purpose motor, the temperature of the motor becomes higher than when it is operated using a commercial power supply. In the low-speed range, the cooling effect will be weakened, so decrease the output torque of the motor. If constant torque is required in the low-speed range, use a Fuji inverter motor or a motor equipped with an externally powered ventilating fan.
- **Vibration**  
Use of an inverter does not increase vibration of a general-purpose motor, but when the motor is mounted to a machine, resonance may be caused by the natural frequencies, including that of the machine system.  
\* The use of a rubber coupling or vibration dampening rubber is recommended.  
\* It is also recommended to use the inverter jump frequency control to avoid resonance points. Note that operation of a 2-pole motor at 60Hz or more may cause abnormal vibration.
- **Noise**  
When an inverter is used with a general-purpose motor, the motor noise level is higher than that with a commercial power supply. To reduce noise, raise carrier frequency of the inverter. High-speed operation at 60Hz or more can also result in more noise.

### In running special motors

- **Explosion-proof motors**  
When driving an explosion-proof motor with an inverter, use a combination of a motor and an inverter that has been approved in advance. Such approved products are available in our special product series. Contact Fuji Electric FA for details.
- **Submersible motors and pumps**  
These motors have a larger rated current than general-purpose motors. Select an inverter whose rated output current is greater than that of the motor. These motors differ from general-purpose motors in thermal characteristics. Set a low value in the thermal time constant of the motor when setting the electronic thermal facility.
- **Brake motors**  
For motors equipped with parallel-connected brakes, their braking power must be supplied from the inverter input side (the primary circuit). If the brake power is connected to the inverter power output side (the secondary circuit) by mistake, problems may occur. Do not use inverters for driving motors equipped with series-connected brakes.
- **Geared motors**  
If the power transmission mechanism uses an oil-lubricated gearbox or speed changer/reducer, then continuous motor operation at low speed may cause poor lubrication. Avoid such operation.
- **Synchronous motors**  
It is necessary to use software suitable for this motor type. Contact Fuji Electric FA for details.
- **Single-phase motors**

Single-phase motors are not suitable for inverter-driven variable speed operation. Use three-phase motors.

\* Even if a single-phase power supply is available, use a three-phase motor as the inverter provides three-phase output.

### Environmental conditions

- **Installation location**  
Use the inverter in a location with an ambient temperature range of -10 to 50°C (14 to 122°F). The inverter heat sinks and braking resistor surfaces become hot under certain operating conditions. Install the inverter on nonflammable material such as metal. Ensure that the installation location meets the environmental conditions specified in "Environment" in Common specifications on page 11. For inverters of 30HP or smaller, remove the ventilation covers when operating it at a temperature of 40°C (104°F) or higher.

### Combination with peripheral devices

- **Installing a molded case circuit breaker (MCCB) or a ground-fault circuit interrupter (GFCI)**  
Install a recommended molded case circuit breaker (MCCB) or a ground-fault circuit interrupter (GFCI) (with the exception of those exclusively designed for protection from ground faults) in the primary circuit of the inverter to protect the wiring. Ensure that the circuit breaker capacity is equivalent to or lower than the recommended capacity.
- **Installing a magnetic contactor (MC) on the inverter power output side (the secondary circuit)**  
If a magnetic contactor (MC) is mounted on the inverter power output side (the secondary circuit) for switching the motor to commercial power or for any other purpose, turn the MC on or off while both the inverter and the motor are fully stopped. Remove the surge suppressor integrated with the MC. For switching operation from/to commercial power supply, use of newly developed "Line/inverter changeover operation" function using terminals such as SW88, SW52-2, SW52-1, SW50, is recommended.
- **Installing a magnetic contactor (MC) on the inverter input side (the primary circuit)**  
Do not turn the magnetic contactor (MC) on the inverter input side (the primary circuit) on or off more than once an hour as an inverter fault may result. If frequent starts or stops are required during motor operation, use FWD/REV signals.
- **Protecting the motor**  
When driving a motor with an inverter, the electronic thermal facility of the inverter can protect the motor. The operation level and the motor type (general-purpose motor, inverter motor) should be set. For high-speed motors or water-cooled motors, set a small value for the thermal time constant to protect the motor, in combination with the "cooling system OFF" signal. When driving several motors with an inverter, connect a thermal relay to each motor and turn on the inverter's electronic thermal relay facility. If you connect the motor thermal relay to the motor with a long cable, a high-frequency current may flow into the wiring stray capacitance. This may cause the relay to trip at a current lower than the set value for the thermal relay. If this happens, lower the carrier frequency or use the output circuit filter (OFL).
- **Discontinuance of power-factor correcting capacitor**  
Do not mount power-factor correcting capacitors in the inverter primary circuit. (Use the DC REACTOR

to improve the inverter power-factor.) Do not use power-factor correcting capacitors in the inverter output circuit. An overcurrent trip will occur, disabling motor operation.

- **Discontinuance of surge killer**  
Do not mount surge killers in the inverter secondary circuit.
- **Reducing noise**  
Use of a filter and shielded wires are typical measures against noise to ensure that EMC Directives are met. Refer to Appendices, App. A "Advantageous Use of Inverters (Notes on electrical noise)" for details.
- **Measures against surge currents**  
If an overvoltage trip occurs while the inverter is stopped or operated under a light load, it is assumed that the surge current is generated by open/close of the phase-advancing capacitor in the power system.  
\* Connect a DC REACTOR to the inverter.
- **Megger test**  
When checking the insulation resistance of the inverter, use a 500V megger and follow the instructions contained in the FRN-G11S/P11S Instruction Manual.

### Wiring

- **Control circuit wiring length**  
When using remote control, limit the wiring length between the inverter and operator box to 65.6ft (20m) or less and use twisted shielded cable.
- **Wiring length between inverter and motor**  
If long wiring is used between the inverter and the motor, the inverter will overheat or trip as a result of overcurrent (high-frequency current flowing into the stray capacitance) in the wires connected to the phases. Ensure that the wiring is shorter than 164ft (50m) for 5HP or less, and shorter than 328ft (100m) for 7.5HP or more. If this length must be exceeded, lower the carrier frequency or mount an output circuit filter (OFL). When wiring is longer than 164ft (50m), and Dynamic torque-vector control or vector with PG is selected, execute off-line auto-tuning.
- **Wiring size**  
Select cables with a sufficient capacity by referring to the current value or recommended wire size.
- **Wiring type**  
Do not use multicore cables.
- **Grounding**  
Securely ground the inverter using the grounding terminal.

### Selecting inverter capacity

- **Driving general-purpose motor**  
Select an inverter according to the applicable motor ratings listed in the standard specifications table for the inverter. When high starting torque is required or quick acceleration or deceleration is required, select an inverter with a capacity one size greater than the standard.
- **Driving special motors**  
Select an inverter that meets the following condition:  
Inverter rated current > Motor rated current

### Transportation and storage

When transporting or storing inverters or inverters while mounted on machines, follow the procedures and select locations that meet the environmental conditions listed in the FRN-G11S/P11S Instruction Manual.

# Fuji Electric FA Components & Systems Co., Ltd.