



Recorder



Flow



Pressure



Temp



Analyzer



Level

Datasheet

Radar level transmitter

WSR700

Supmea[®]

Committed to process automation solutions

Tel: 86-15158063876

E-mail: info@supmea.com

www.supmea.com

Datasheet**Level radar transmitter
WSR700**

The 76-81GHz series products refer to frequency modulated continuous wave (FMCW) radar products operating at 76-81GHz, supporting four-wire and two-wire applications. The product has multiple models, the range can reach 120m, and the blind zone can reach 8 cm. Because of its higher operating frequency and shorter wavelength, it is especially suitable for solid applications. The working method of transmitting and receiving electromagnetic waves through the lens has unique advantages in high dust and harsh temperature environments (+200°C). The instrument provides flange or thread connection, which makes installation convenient and easy.

Applications

- Chemical industry
- Solids level measurement
- Sewage treatment
- Mining industry
- Paper and Pulp Industry
- Boiler Engineering
- Liquid and solid powder measure
- Acids, bases or other corrosive media

Features

- Range: M1-10m, M2-20m, M3-30M, M6-60m, MB-120m
- Can be used in stirring, steam, dust, crystallization occasions
- Abundant physical interfaces: 4~20mA (2 channels optional), HART,AUTBUS
- Fieldbus Foundation, ProfibusPA, NB-IoT, etc.
- Support Bluetooth debugging function
- Support low dielectric constant (less than 1.5) medium TBF tank bottom reflection measurement
- Support backlight display

**WSR700**

Principle

High-frequency microwave pulses issued by the guided wave radar propagate along detection components (steel cable or steel rod), meet the media to be measured, since the dielectric constant of the mutation, cause reflections, a portion of the pulse energy is reflected back. Transmit pulse and the reflected pulse is proportional to the distance and the time interval measured media.

Explanation:

H--- Measuring range

L---Empty distance

B---The top of the blind

E---The minimum distance from the probe to the tank wall

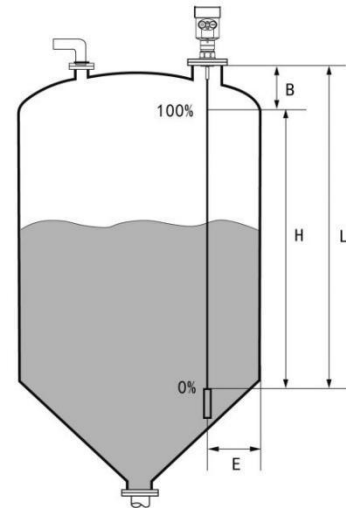

--Blind spot is the minimum distance between the top of the highest material surface materials and measurement reference point.

--The bottom of the blind refers to a distance near the very bottom of the cable can not be accurately measured.

--Between the top and bottom of the blind is blind effective measure distances.

Note:

In order to ensure the accuracy of level measurement, the material should be located between the top and bottom of the blind the blind.

Parameters	
Transmit frequency	76GHz~81GHz
Range	0.08 m ~10m; 0.08~20m; 0.08 m ~30m; 0.3 m~60m; 0.6 m~120m
Accuracy	±1mm
Measurement interval	Fastest 100ms
Beam angle	3°/8°/20°
Dielectric constant range	≥2
Power supply	12~28VDC
Communication	MODBUS, HART
Signal output	4~20mA or RS-485
Fault output	3.8mA, 4mA, 20mA, 21mA, hold
On-site operation/programming	128×64 dot matrix display/4 buttons; configurable host computer setting software
Industrial temperature/humidity	T0:-40~85℃/humidity≤95%RH; T1:-40~200℃; T2:-40~500℃; T3:-40~1000℃
Shell material	Aluminum alloy, stainless steel
Process connection	Pipe thread/universal flange/anti-corrosion flange/sanitary chuck/quartz isolation flange
Process pressure	-0.1~2MPa
Dimension	φ 100*270mm
Connection	M20*1.5
Recommended wire	AWG18 or 0.75mm ²
Ingress protection	IP67
Mounting method	Thread or flange

Dimension

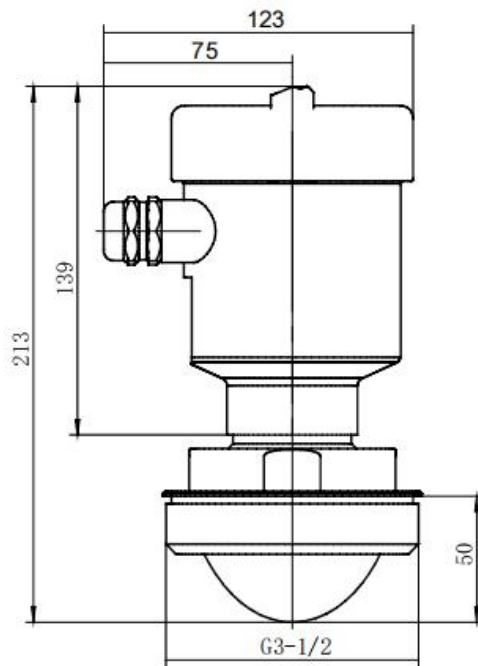

Normal temperature pipe threaded connection

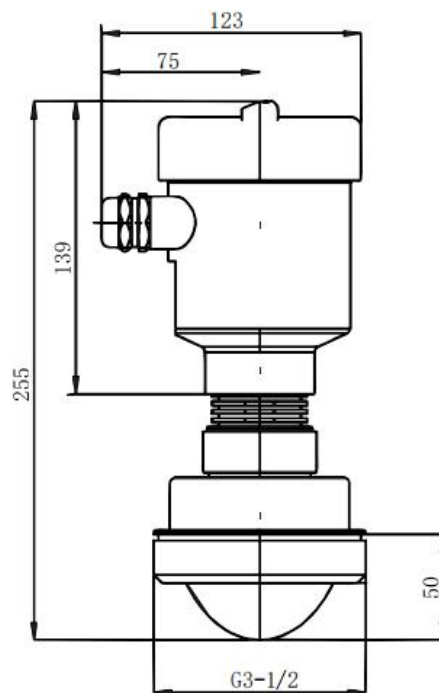

Note: This model needs to be equipped with a high temperature version of the electronic module
High temperature (-40...200°C) pipe thread connection

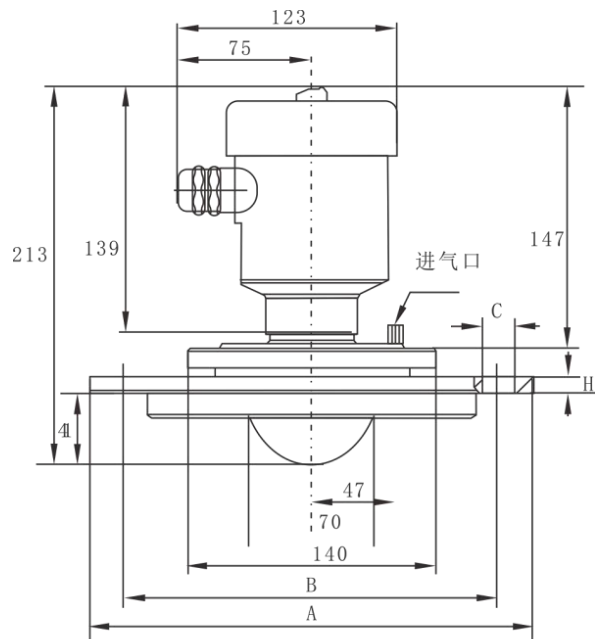

	A	B	C	H
DN80	φ 190	φ 150	4-φ 18	15
DN100	φ 210	φ 170	4-φ 18	15
DN125	φ 240	φ 200	8-φ 18	17
DN150	φ 265	φ 225	8-φ 18	17
DN200	φ 320	φ 280	8-φ 18	19

Normal temperature universal flange structure

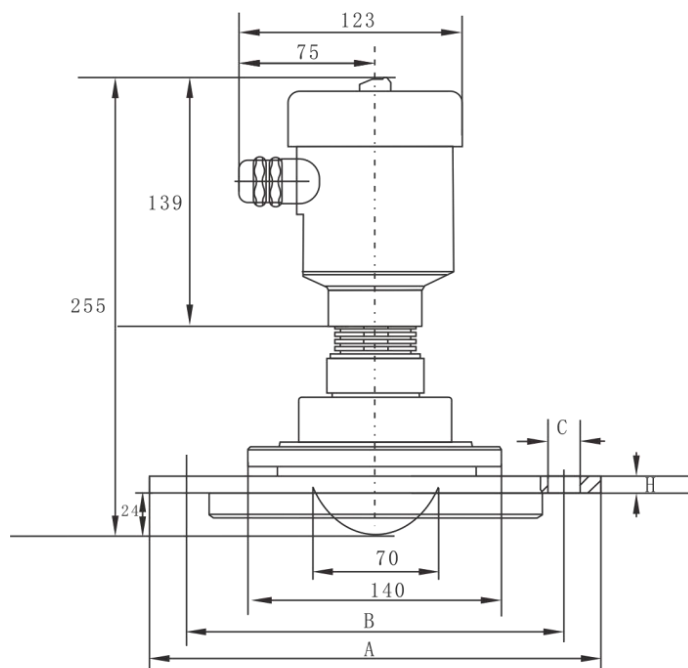

	A	B	C	H
DN80	φ 190	φ 150	4-φ 18	15
DN100	φ 210	φ 170	4-φ 18	15
DN125	φ 240	φ 200	8-φ 18	17
DN150	φ 265	φ 225	8-φ 18	17
DN200	φ 320	φ 280	8-φ 18	19

High temperature (-40...200°C) universal flange structure

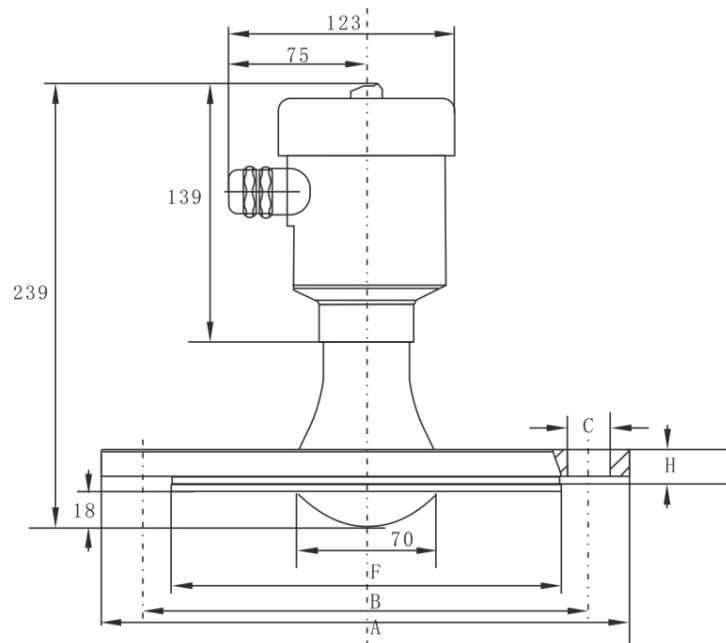

	A	B	C	F	H
DN80	φ 190	φ 150	4-φ 18	φ 128	18
DN100	φ 210	φ 170	4-φ 18	φ 148	18
DN125	φ 240	φ 200	8-φ 18	φ 178	20
DN150	φ 265	φ 225	8-φ 18	φ 202	20
DN200	φ 320	φ 280	8-φ 18	φ 258	22

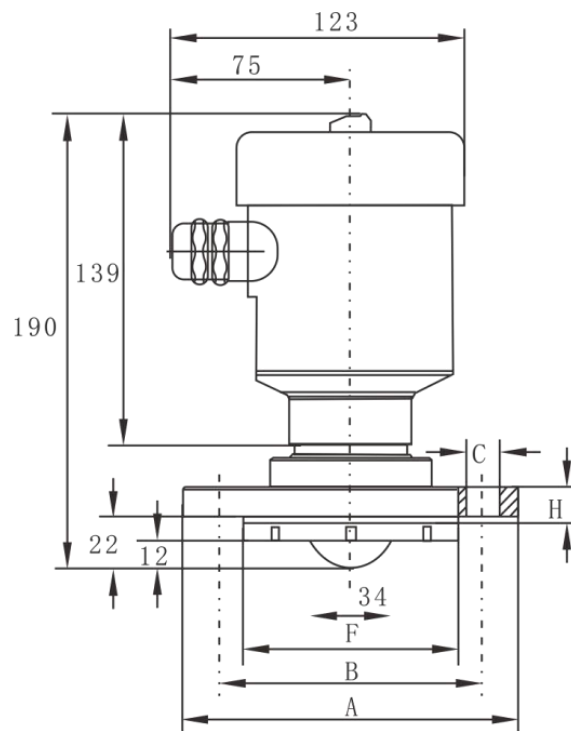

	A	B	C	F	H
DN50	φ 140	φ 110	4-φ 14	φ 90	16
DN100	φ 160	φ 130	4-φ 14	φ 110	16

Normal temperature anti-corrosion flange structure

Ordering code

WSR700-B-10-A-G1-A-1-A														Description	
WSR700	-	-	-	-	-	-	-	-	-	-	-	-	-	-	Liquid
Medium	A														Solid Powder
	B														
Range		10													10m
		20													20m
		30													30m
		60													60m
		XX													Other
Output and power supply			A2												Two-wire 4-20mA+HART
			SE												4-20mA+RS485, 24VDC
			B3												Two-wire 4-20mA+HART+Bluetooth
			B5												4-20mA+RS485+Bluetooth, 24VDC
			B4												Two-wire 4-20mA+HART+Bluetooth, 220VAC
		B6												4-20mA+RS485+Bluetooth, 220VAC	
Thread Type			LB												G1 1/2
			LE												HG/T20592 PN10 DN50
			FP												HG/T20592 PN10 DN80
			FQ												HG/T20592 PN10 DN100
			FR												HG/T20592 PN10 DN125
			FS												HG/T20592 PN10 DN150
			FT												HG/T20592 PN10 DN80 Swivel
			FU												HG/T20592 PN10 DN100 Swivel
			FV												HG/T20592 PN10 DN150 Swivel
		FW												HG/T20592 PN10	

	XX								DN150 Swivel
									Other
	1								Polytetrafluoroethylene (PTFE), 304SS
Antenna and Thread Type	2								Polytetrafluoroethylene (PTFE), SS316L
Material	3								Polytetrafluoroethylene (PTFE)
	9								Other
		TC							'-40-80°C
High Temperature Resistance		TF							'-40-150°C
		XX							Other
			EJ						Plastic ABS Air Duster
Accessories			EM						Installation bracket 304SS